

# CITY OF EULESS, TEXAS FINAL CONSTRUCTION PLANS TO SERVE NEPALI CULTURE AND SPIRITUAL CENTER

## TXDOT NOTES

- ALL CONSTRUCTION WITHIN THE STATE RIGHT OF WAY WILL REQUIRE COMPLIANCE TO TXDOT STANDARD SPECIFICATIONS, STANDARD PLANS, AND TEXAS MANUAL ON UNIFORM TRAFFIC CONTROL DEVICES.
- SPECIFICATIONS ADOPTED BY THE TEXAS DEPARTMENT OF TRANSPORTATION, NOVEMBER 1, 2014 AND SPECIFICATION ITEMS LISTED AS FOLLOWS SHALL GOVERN ON THIS PROJECT FOR ALL WORK WITHIN THE STATE RIGHT OF WAY.
- THE STANDARD SHEETS, SPECIFICALLY IDENTIFIED IN THIS INDEX OF SHEETS, HAVE BEEN SELECTED BY ME OR UNDER MY RESPONSIBLE SUPERVISION AS BEING APPLICABLE TO THIS PROJECT.(STANDARD PLAN SHEETS ARE IDENTIFIED WITH AN \* IN THE INDEX SHEETS.)
- BY SEALING AND SIGNING THESE PERMIT PLANS AS A PROFESSIONAL CIVIL ENGINEER LICENSED TO PRACTICE IN THE STATE OF TEXAS, I CERTIFY THAT THE PROPOSED DRIVEWAY OR PUBLIC STREET CONNECTION(S) TO THE STATE ROADWAY MEETS OR EXCEEDS THE MINIMUM STOPPING DISTANCE REQUIRED FOR A POSTED SPEED OF 50 MPH, BASED ON THE MOST RECENT TXDOT DESIGN MANUAL REQUIREMENTS."
- FULL-DEPTH SAW CUT ALL JOINTS MADE FOR REMOVAL OF EXISTING STATE FACILITIES.
- SINGLE LANE CLOSURES WILL BE RESTRICTED TO OFF-PEAK HOURS AS DEFINED IN THE FOLLOWING:  
9:00 AM TO 3:00 PM AND 7:00 PM TO 6:00 AM MONDAY THROUGH FRIDAY  
ALL DAY SATURDAY AND SUNDAY

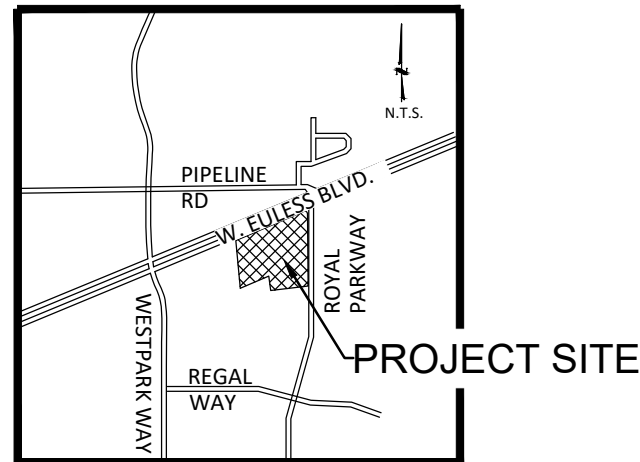

**VICINITY MAP**  
*NOT TO SCALE*

## SHEET INDEX

SHEET NO	DESCRIPTION
1	COVER SHEET
2	GENERAL NOTES
3	EXISTING SURVEY
4	SITE PLAN
5	DEMOLITION PLAN
6	HORIZONTAL CONTROL
7-8	GRADING PLAN
9	EXISTING DRAINAGE AREA MAP
10	PROPOSED DRAINAGE AREA MAP
11	STORM DRAIN PLAN
12	STORM DRAIN PROFILES
13	STORM DRAIN CALCULATIONS
14	POND CALCULATIONS
15	PAVING PLAN
16	WATER AND SEWER PLAN
17	EROSION CONTROL PLAN
18	TRAFFIC CONTROL PLAN
19	SITE DETAILS & SECTIONS
20-22	LANDSCAPE AND IRRIGATION PLANS
23	LIGHTING PLAN
*	STANDARD DETAILS
*	PEDESTRIAN HANDRAIL DETAILS
*	CONCRETE HEADWALL
*	PEDESTRIAN FACILITIES CURB RAMPS
*	TCP(1-4) - 18
*	TCP(2-1) - 18
*	CP-TEP(FTW)
*	EDGE CONDITION TREATMENT TYPES

### LEGEND

	RETAINING WALL
	HANDRAIL
	EXIST. CONTOUR
	PROPOSED CONTOUR
	EXISTING FENCE
	EXIST. WATER MAIN
	EXIST. SEWER MAIN
	EXIST. STORM MAIN
	FLOW DIRECTION
	SAWCUT, REMOVE AND REPLACE
	PROP. 4" CONCRETE
	PROP 5" PAVEMENT
	PROP 6" PAVEMENT

### ABBREVIATION

TC	TOP OF CURB
TP	TOP OF PAVEMENT
FS	FINISH SURFACE
FG	FINISH GRADE
CF	CURB FACE
FL	FLOWLINE
HP	HIGH POINT
LP	LOW POINT
TG	TOP OF GRATE
GB	GRADE BREAK
PL	PROPERTY LINE
R/W	RIGHT OF WAY
(495.2)	EXISTING ELEVATIONS
TRW	TOP OF RETAINING WALL
TF	TOP OF FOOTING
RH	RETAINED HEIGHT

### FEMA FLOOD ZONE:

FLOOD ZONE: "X" PER  
MAP NO 48439C0230L,  
EFFECTIVE ON 03/21/2019

### Owned By:

NEPALI CULTURAL AND SPIRITUAL CENTER  
1212 ROYAL PARKWAY  
EULESS, TEXAS 76040

### BENCHMARK

#### (EULESS CONTROL MONUMENT E04)

ELEVATION: 562.857' NGVD1929

#### NAD 1983 DATUM

NORTHING: 6986180.789

EASTING: 2395878.716

DESCRIPTION: 3-1/4" DOMED BRASS DISK SET IN TOP OF A CONCRETE INLET AND WITNESS BY AN ORANGE FIBERGLASS STAKE.

### BENCHMARK

#### (EULESS CONTROL MONUMENT E03)

ELEVATION: 535.794' NGVD1929

#### NAD 1983 DATUM

NORTHING: 6985189.443

EASTING: 2398570.777

DESCRIPTION: 3-1/4" DOMED BRASS DISK SET IN TOP OF AN INLET NEAR THE SOUTHWEST CORNER OF THE INLET.

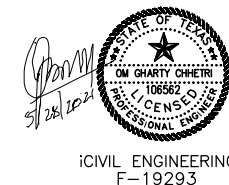

iCIVIL ENGINEERING  
F-19293

### Prepared By:

iCIVIL Engineering  
202 Republic Ln  
Euless, Tx 76040  
Tel.(972) 523-5493  
TBPE:F-19293

**GENERAL NOTES**

- ALL WORK SHALL BE DONE IN ACCORDANCE WITH THE CURRENT CITY STANDARDS AND SPECIFICATIONS AND THE NORTH CENTRAL TEXAS COUNCIL OF GOVERNMENTS (NCTCOG) "STANDARD SPECIFICATIONS FOR PUBLIC WORKS CONSTRUCTION" ALONG WITH ALL OF THE LATEST AMENDMENTS. COPIES MAY BE OBTAINED FROM THE "NORTH CENTRAL TEXAS COUNCIL OF GOVERNMENTS", PO DRAWER 5888, ARLINGTON, TEXAS, 76005- 5888, PHONE (817) 640-3300; ALSO AVAILABLE AT [HTTPS://WWW.NCTCOG.ORG/ENVIR/PUBLIC-WORKS/CONSTRUCTION- STANDARDS](https://www.nctcog.org/envir/public-works/construction-standards). A COPY OF THE CONTRACT DOCUMENTS, PLANS AND SPECIFICATIONS SHALL BE AVAILABLE ON-SITE AT ALL TIMES BY THE CONTRACTOR.
- ALL COMMUNICATION BETWEEN THE CITY AND THE CONTRACTOR SHALL BE THROUGH THE ENGINEERING CONSTRUCTION INSPECTOR AND ENGINEER OF RECORD ONLY. IT IS THE RESPONSIBILITY OF THE CONTRACTOR TO CONTACT THE APPROPRIATE DEPARTMENT FOR INSPECTIONS OF WORK NOT FALLING UNDER THE PUBLIC WORKS CONSTRUCTION PERMIT.
- THE LOCATION AND DEPTH OF ALL UTILITIES SHOWN ON THE PLANS ARE APPROXIMATE AND THERE MAY BE OTHER UNKNOWN EXISTING UTILITIES NOT SHOWN ON THE PLANS. ALL EXISTING UTILITIES SHALL BE FIELD VERIFIED AND PROTECTED BY THE CONTRACTOR PRIOR TO THE START OF CONSTRUCTION. (ALSO SEE GENERAL NOTE NO. 4(D)). THE CONTRACTOR SHALL CONTACT THE FOLLOWING UTILITY COMPANIES 72 HOURS PRIOR TO DOING ANY WORK IN THE AREA:  
 A.ATMOS GAS LINE LOCATIONPH (817) 303-2914  
 B.ONCOR ELECTRIC DELIVERYPH (972) 923-4245  
 C.AT&T TELEPHONE CO. LINE LOCATION PH (972) 660-0422  
 D.TIME WARNER CABLE COMPANY LINE LOCATION PH (214) 320-7396  
 E.VERIZON PH (800) 624-9675  
 F.U.S. SPRINT PH (800) 521-0579  
 G.AT&T PH (800) 252-1133  
 H.TEXAS DEPARTMENT OF TRANSPORTATION (TARRANT AREA) PH (817) 370-6500  
 I. DIG TESS PH (800) 344-8377
- IT SHALL BE THE RESPONSIBILITY OF THE CONTRACTOR TO PERFORM THE FOLLOWING:
  - PREVENT ANY PROPERTY DAMAGE TO PROPERTY OWNER'S POLES, FENCES, SHRUBS, MAILBOXES, ETC
  - LOCATE, VERIFY WORKING CONDITION AND PROTECT ALL EXISTING SPRINKLER SYSTEMS LINES AND HEADS (IF ANY) WITHIN AREAS DISTURBED BY CONSTRUCTION ACTIVITIES. REMOVE, ADJUST AND REINSTALL IN GOOD CONDITION EQUAL TO OR BETTER THAN EXISTING CONDITION; REPLACE, IF IN DIRECT CONFLICT, WITH THE SAME OR BETTER QUALITY MATERIAL AND APPURTENANCES, ALL AT THE CONTRACTOR'S OWN EXPENSE.
  - PROVIDE ACCESS TO ALL DRIVES DURING CONSTRUCTION.
  - PROTECT ALL UNDERGROUND AND OVERHEAD UTILITIES AND REPAIR ANY DAMAGES. (ALSO SEE GENERAL NOTE NO. 3.)
  - NOTIFY ALL UTILITY COMPANIES AND VERIFY LOCATION OF ALL UTILITIES PRIOR TO THE START OF CONSTRUCTION.
  - PROVIDE CONSTRUCTION STAKING OF PUBLIC IMPROVEMENTS CONSTRUCTED WITHIN ANY CITY EASEMENT OR RIGHT-OF-WAY. STAKING SHALL BE PERFORMED BY A SURVEYOR LICENSED IN THE STATE OF TEXAS.
  - COOPERATE WITH THE UTILITY COMPANIES WHERE UTILITIES ARE REQUIRED OR SPECIFIED TO BE RELOCATED.
  - WORK IN CLOSE PROXIMITY TO AND PROTECT EXISTING UTILITY MAINS, TRAFFIC LIGHTS AND POLES.
  - ANY ITEM NOT SPECIFICALLY CALLED OUT TO BE REMOVED SHALL BE BROUGHT TO THE ATTENTION OF THE ENGINEER OF RECORD PRIOR TO REMOVING THAT ITEM OR IT SHALL BE REPLACED AT THE CONTRACTOR'S OWN EXPENSE.
  - ANY TREE, SHRUB, OR GRASSED AREAS DAMAGED BY THE CONTRACTOR'S WORK SHALL BE REPLACED AT THE CONTRACTOR'S EXPENSE TO EXISTING OR BETTER CONDITION.
  - IN THE PREPARATION OF THE PLANS AND SPECIFICATIONS, THE ENGINEER OF RECORD HAS ENDEAVORED TO INDICATE THE LOCATION OF EXISTING UNDERGROUND UTILITIES. IT IS NOT GUARANTEED THAT ALL LINES OR STRUCTURES HAVE BEEN SHOWN ON THE PLANS. THE CONTRACTOR SHALL REQUEST FOR LINE LOCATES AS DIRECTED IN ITEM #3. THE ENGINEER OF RECORD SHALL BE NOTIFIED ABOUT ANY CONFLICTS TO PROVIDE WRITTEN DIRECTION AND REVISED PLANS AS REQUIRED.
  - VERIFICATION OF THE CONDITION OF EXISTING CITY UTILITIES PRIOR TO CONNECTIONS SHALL BE THE RESPONSIBILITY OF THE CONTRACTOR. THE CONTRACTOR SHALL REQUEST FOR LINE LOCATES AS DIRECTED IN ITEM #3.
  - THE LOCATION FOR THE DISPOSAL OF CONSTRUCTION MATERIAL AND SPOILS SHALL BE ACCEPTED BY THE CITY OF ENGINEERING DIVISION PRIOR TO THE START OF CONSTRUCTION AS REFLECTED WITHIN THE STORMWATER POLLUTION PREVENTION PLAN.
  - ALL PHASES OF CONSTRUCTION MUST BE COORDINATED WITH THE ENGINEER OF RECORD. ALSO, THE CONTRACTOR IS REQUIRED TO COORDINATE WITH THE ADJACENT PROPERTY OWNERS AND THE CITY IN ORDER TO MINIMIZE CONFLICTS IN TRAFFIC FLOW OR OTHER OPERATIONS.
  - IT SHALL BE UNLAWFUL FOR ANY PERSON TO LAY, CONSTRUCT, BUILD, GRADE, GRAVEL, PAVE, SURFACE, EXCAVATE, RESURFACE, OR DO ANY WORK IN OR UPON ANY PUBLIC STREET, ALLEY, EASEMENT, THOROUGHFARE, PUBLIC PLACE, OR CONNECT TO PUBLIC WATER AND WASTEWATER MAINS WITHIN THE CITY, WITHOUT FIRST HAVING OBTAINED A PERMIT TO DO SUCH WORK FROM THE DIRECTOR OF PUBLIC WORKS, AND WITHOUT HAVING PAID A PERMIT FEE TO THE CITY. THE PERMITTEE SHALL NOTIFY THE ENGINEERING DEPARTMENT OF THE CONSTRUCTION STARTUP DATE AND AN EXPECTED COMPLETION DATE.
  - FIELD ADJUSTMENTS MAY BE NECESSARY AND SHALL BE CARRIED OUT AS DIRECTED IN WRITTEN FORM, AND REVISED PLANS AS NEEDED, BY THE ENGINEER OF RECORD. THE ADJUSTMENTS SHALL BE COORDINATED WITH THE CONTRACTOR AND THE ENGINEERING CONSTRUCTION INSPECTOR.
  - THE CONTRACTOR SHALL VERIFY, LOCATE, AND PROTECT EXISTING WATER, WASTEWATER, FIBER OPTIC CABLE/PATHWAYS (CITY AND FRANCHISE UTILITY), TRAFFIC SIGNALS AND APPURTENANCES, STORM DRAINAGE, NATURAL GAS, PETROLEUM PIPELINES, ELECTRIC AND TELEPHONE MAINS AND SERVICES AND RESTORE SERVICE IN CASE OF ANY DAMAGE.
  - ALL FENCES, SIGNS, SURVEY MONUMENTS, AND PROPERTY CORNER MONUMENTS REMOVED OR DAMAGED DURING CONSTRUCTION SHALL BE REPLACED WITH NEW MATERIAL IN CONFORMANCE WITH THE CITY ENGINEER'S SPECIFICATIONS.
  - THE CONTRACTOR SHALL BE RESPONSIBLE FOR TAKING ALL PRECAUTIONS TO PROTECT EXISTING TREES OUTSIDE THE SCOPE OF THIS PROJECT OR THOSE TREES NOT DESIGNATED IN THE PLANS TO BE REMOVED.
  - THE CONTRACTOR SHALL BE RESPONSIBLE FOR REPAIRING ANY DAMAGE CAUSED BY THE CONTRACTOR OUTSIDE OF THE DESIGNATED WORK AREA WITH NEW QUALITY MATERIAL AT THE CONTRACTOR'S EXPENSE.
  - THE PERMITTED CONTRACTOR MAKING CONNECTIONS/EXTENSIONS TO EXISTING PUBLIC UTILITIES SHALL BE SOLELY RESPONSIBLE FOR BACKFILL OF THE UTILITY TRENCH, AND ANY PAVING REPAIRS REQUIRED FOR COMPLETION OF THE CONNECTION/EXTENSION. ALL PAVING REPAIRS SHALL COMPLY WITH THE CURRENT CITY STANDARD DETAILS. THIRD PARTY WORK, NOT COVERED BY THE PERMITTEES PERMIT AND MAINTENANCE BOND, SHALL NOT BE ACCEPTED.
  - SHEETING, SHORING, AND BRACING: THE CONTRACTOR WILL ABIDE BY ALL APPLICABLE FEDERAL, STATE, AND LOCAL LAWS GOVERNING EXCAVATION. TRENCH'S SIDE SLOPES SHALL MEET OCCUPATIONAL SAFETY AND HEALTH ADMINISTRATION (OSHA) STANDARDS THAT ARE IN EFFECT AT THE TIME OF CONSTRUCTION. SHEETING SHORING AND BRACING SHALL BE REQUIRED IF SIDE SLOPE STANDARDS ARE NOT MET. A PULL BOX, MEETING OSHA STANDARDS, WILL BE ACCEPTABLE. THE CONTRACTOR SHALL SUBMIT SITE SPECIFIC, DETAILED PLANS AND SPECIFICATIONS FOR TRENCH SAFETY SYSTEMS THAT MEET OSHA STANDARDS HAT ARE IN EFFECT AT THE TIME OF DEVELOPMENT OF PROJECT WHEN TRENCH EXCAVATION WILL EXCEED A DEPTH OF FIVE (5) FEET. THESE PLANS WILL BE SEALED BY AN ENGINEER REGISTERED BY THE STATE OF TEXAS AND SUBMITTED TO THE CITY PRIOR TO OBTAINING RELEASE OF THE PUBLIC WORKS CONSTRUCTION PERMIT.
  - THE CONTRACTOR SHALL SUBMIT MIX DESIGNS FOR CONCRETE AND GROUT FOR REVIEW AND ACCEPTANCE BY THE CITY PRIOR TO ANY PLACEMENT FOR ANY PUBLICLY DEDICATED INFRASTRUCTURE.
  - ALL EXISTING GRADES SHOWN ON THE PLANS ARE APPROXIMATE AND ARE BASED ON THE BEST INFORMATION AVAILABLE. GRADES SHALL BE VERIFIED AND ANY DISCREPANCY BROUGHT TO THE ATTENTION OF THE ENGINEER OF RECORD FOR EVALUATION AND ADJUSTMENTS AS NEEDED.
  - ALL BACKFILL FOR DITCH LINES ARE TO BE MECHANICALLY TAMPED TO 95% STD PROCTOR DENSITY (ASTM D698), AT A MOISTURE CONTENT NEAR OPTIMUM (-2% TO +2%, OR AS SPECIFIED BY THE ENGINEER OF RECORD). COSTS OF TESTING SERVICES FOR PRIVATE DEVELOPMENT, ON INFRASTRUCTURE THAT IS TO BE DEDICATED TO THE CITY, SHALL BE PAID BY THE DEVELOPER/CONTRACTOR. TESTING SHALL COMPLY WITH THE CITY STANDARDS AND THE CURRENT STANDARD DETAILS. ALL TEST REPORTS FOR PUBLIC INFRASTRUCTURE SHALL BE PROVIDED TO THE CITY IN A TIMELY MANNER. COSTS FOR RE-TESTING AFTER NOTED FAILURES SHALL BE THE RESPONSIBILITY OF THE CONTRACTOR.
  - CONTRACTOR TO FILL ALL VOIDS UNDER EXISTING PAVEMENT WHEN INSTALLING NEW LINE. ALSO ALL DITCH LINES MUST BE FILLED AT THE END OF EACH DAY'S WORK. CONTRACTOR SHALL OBTAIN APPROVAL FROM THE PROPER CITY DEPARTMENTS FOR ANY TRENCHES THAT ARE TO LEFT OPEN OVERNIGHT AND SHALL PROPERLY MARK AND PROTECT THE TRENCH.
  - ALL PIPES SHALL BE KEPT FREE OF TRASH AND DIRT AT ALL TIME. AT THE END OF EACH DAY, THE PIPE SHALL BE TEMPORARILY SEALED/CONNECTED. ALL PIPE INSTALLATION SHALL BE PERFORMED AS RECOMMENDED PER THE PIPE MANUFACTURER.
  - THE CONTRACTOR SHALL KEEP THE EXISTING FIRE HYDRANT(S) IN SERVICE AT ALL TIMES, TO THE EXTENT POSSIBLE. THE CONTRACTOR SHALL BAG OR MARK FIRE HYDRANTS PROPERTY AND NOTIFY THE FIRE DEPARTMENT UPON REMOVING ANY HYDRANT FROM SERVICE. CONSTRUCTION THAT CAUSES THE INTERRUPTION OF WATER SUPPLY FOR FIRE SUPPRESSION MAY REQUIRE A FIRE WATCH TO BE PERFORMED BY THE FIRE DEPARTMENT. COSTS FOR FIRE WATCH SERVICES ARE AT THE CONTRACTOR'S EXPENSE.
  - THE CONTRACTOR SHALL MAINTAIN THE EXISTING WATER MAINS IN SERVICE DURING ALL PHASES OF CONSTRUCTION. LEAKS CAUSED BY THE CONTRACTOR SHALL BE REPAIRED IMMEDIATELY AT THE CONTRACTOR'S EXPENSE. LEAKS ALONG THE EXISTING WATER MAIN CLOSE TO THE WORKING AREA, CAUSED BY VIBRATION, ETC. (DURING WORKING HOURS) SHALL BE REPAIRED BY THE CONTRACTOR WITH THE CITY ONLY PROVIDING THE REQUIRED PARTS. THE CITY WILL REPAIR ALL LEAKS IF THE CONTRACTOR IS NOT ON THE JOB-SITE (PRIMARILY AFTER WORKING HOURS); IF THE LEAK IS DIRECTLY CAUSED BY THE CONTRACTOR AND NOT REPAIRED, ALL CHARGES INCURRED SHALL BE BILLED TO THE CONTRACTOR.
  - ALL CUTTING AND PLUGGING OF THE EXISTING WATER MAIN, WHERE SPECIFIED ON THE PLANS, SHALL INCLUDE ALL LABOR, FITTINGS AND APPURTENANCES REQUIRED TO PERFORM THIS WORK.
  - THE CONTRACTOR SHALL CONTACT THE ASSIGNED INSPECTOR FOR THE OPERATION OF ALL WATER VALVES & SCHEDULING OF SERVICES BY WATER/WASTEWATER.
  - THE CONTRACTOR SHALL MAINTAIN THE EXISTING WATER MAINS AND SERVICES IN OPERATION WHEN INSTALLING NEW WATER MAINS. THIS SHALL INCLUDE ANY TEMPORARY CONNECTIONS, IF REQUIRED.
  - THE CONTRACTOR MUST NOTIFY EACH PROPERTY OWNER A MINIMUM OF 24 HOURS PRIOR TO SHUTTING OFF WATER FOR CONNECTION TO NEW MAIN. THE CONTRACTOR SHALL NOTIFY THE ENGINEERING CONSTRUCTION INSPECTOR A MINIMUM OF 72 HOURS IN ADVANCE FOR ALL WATER OR WASTEWATER LOCATES OR SHUT OFFS OF WATER. THE LENGTH OF TIME FOR WATER SHUTDOWNS SHALL BE LIMITED TO AS NEEDED TO PERFORM THE REQUIRED WORK.
  - THE CONTRACTOR SHALL MAINTAIN THE EXISTING WASTEWATER MAINS AND SERVICES IN OPERATION WHEN INSTALLING NEW WASTEWATER MAINS. THIS SHALL INCLUDE ANY TEMPORARY CONNECTIONS, IF REQUIRED.
  - THE MAXIMUM DEFLECTION OF PIPE JOINTS SHALL NOT EXCEED THAT RECOMMENDED BY THE PIPE MANUFACTURE. IF IT IS NECESSARY TO DEFLECT THE PIPE (GREATER THAT THE RECOMMENDED AMOUNT) THE CONTRACTOR SHALL PROVIDE FITTINGS AS NEEDED.
  - PRIOR TO THE START OF CONSTRUCTION, THE ENGINEERING CONSTRUCTION INSPECTOR, CITY WATER/WASTEWATER REPRESENTATIVE AND THE CONTRACTOR SHALL MAKE A DRY RUN TO THE SYSTEM TO INSURE, TO THE EXTENT POSSIBLE, THAT THE UTILITY CAN BE FOUND AND SECURED. ANY ISSUES SHALL BE BROUGHT TO THE ATTENTION OF THE ENGINEER OF RECORD TO PROVIDE WRITTEN DIRECTION AND PROVIDE REVISED PLANS AS NEEDED.
  - TRAFFIC CONTROL PLANS SHALL BE SUBMITTED TO THE CITY TRANSPORTATION SERVICES DEPARTMENT/TxDOT. THE TRAFFIC CONTROL PLAN AND BARRICADES SHALL MAINTAIN TRAFFIC FLOW AND SHALL BE IN ACCORDANCE WITH THE LATEST EDITION OF THE TMTUCD AND PREPARED BY A WORK ZONE CERTIFIED TECHNICIAN. TRAFFIC CONTROL PLANS SHALL BE SUBMITTED A MINIMUM OF TWO WEEKS IN ADVANCE OF WORK COMMENCING. TEMPORARY STREET CLOSURE REQUESTS SHALL BE SUBMITTED IN WRITING.
  - ALL PAVEMENT MARKINGS, INCLUDING RAISED PAVEMENT MARKERS, LANE STRIPING, TRANSVERSE MARKINGS, SIGNS AND OTHER TRAFFIC CONTROL DEVICES, DISTURBED DURING CONSTRUCTION SHALL BE MAINTAINED, REPAIRED OR REPLACED AT THE CONTRACTOR'S EXPENSE.
  - ALL DETENTION/RETENTION BASINS SHALL BE SODDED WITH GRASS, LANDSCAPED, AND IRRIGATED IN ACCORDANCE WITH CITY STANDARDS. ALL SUCH BASINS SHALL HAVE A DRAINAGE AND DETENTION EASEMENT DEDICATED TO THE CITY, INCORPORATING THE BASIN AND THE OUTFALL SYSTEM(S) THAT CONVEYS STORM FLOWS TO THE PUBLIC STORM DRAIN SYSTEM. THE OWNER/DEVELOPER (HEIRS AND ASSIGNS) SHALL BE BOUND WITH OPERATIONS AND MAINTENANCE OF ALL SUCH BASINS.
  - SEED/SOD SHALL BE FURNISHED TO ESTABLISH GROUND COVER OVER ALL DISTURBED AREAS AS AN EROSION CONTROL MEASURE. THE CONTRACTOR SHALL NOT WAIT UNTIL THE COMPLETION OF THE ENTIRE PROJECT BEFORE DOING THIS WORK.

**WATER AND SANITARY SEWER GENERAL NOTES**

- UNLESS OTHERWISE NOTED ALL MATERIALS AND CONSTRUCTION SHALL CONFORM TO THE APPLICABLE SPECIFICATIONS AND STANDARDS OF THE CITY OF EULESS AND THE NORTH CENTRAL TEXAS COUNCIL OF GOVERNMENTS - "STANDARD SPECIFICATIONS FOR PUBLIC WORKS CONSTRUCTION" LATEST EDITION.
- ALL SANITARY SEWER AND WATER MAIN CONSTRUCTION WITHIN PUBLIC RIGHT-OF-WAY OR EASEMENT SHALL CONFORM TO THE REQUIREMENTS OF THE TEXAS COMMISSION ON ENVIRONMENTAL QUALITY (TCEQ) GUIDELINES FOR CONSTRUCTION OF PUBLIC WATER AND SEWER SYSTEMS. CONTRACTOR SHALL MAINTAIN A COPY OF THE DESIGN DOCUMENTS AT THE JOBSITE AT ALL TIMES.
- CONTRACTOR SHALL MAINTAIN EXISTING SANITARY SEWER AND WATER SERVICE AT ALL TIMES DURING CONSTRUCTION.
- THE LOCATIONS, ELEVATIONS AND DIMENSIONS OF EXISTING UTILITIES SHOWN ON THE PLANS WERE OBTAINED FROM AVAILABLE CITY AND UTILITY COMPANY RECORDS AND PLANS, AND ARE CONSIDERED APPROXIMATE. IT SHALL BE THE CONTRACTOR'S RESPONSIBILITY TO VERIFY ALL LOCATIONS, ELEVATIONS AND DIMENSIONS OF ADJACENT AND/OR CONFLICTING UTILITIES SUFFICIENTLY IN ADVANCE OF CONSTRUCTION IN ORDER THAT ADJUSTMENTS CAN BE MADE TO PROVIDE ADEQUATE CLEARANCES. THE CONTRACTOR SHALL PRESERVE AND PROTECT PUBLIC UTILITIES AT ALL TIMES DURING CONSTRUCTION. ANY DAMAGE TO UTILITIES RESULTING FROM CONTRACTOR'S OPERATIONS SHALL BE RESTORED AT HIS EXPENSE. THE CITY OF EULESS ENGINEERING DEPARTMENT SHALL BE NOTIFIED WHEN PROPOSED SANITARY SEWER OR WATER LINE GRADES CONFLICT WITH EXISTING UTILITY LINES. AT LEAST FORTY-EIGHT (48) HOURS PRIOR TO BEGINNING CONSTRUCTION IN THE VICINITY OF EXISTING UTILITIES, THE CONTRACTOR SHALL NOTIFY UTILITY COMPANIES TO LOCATE ALL UNDERGROUND UTILITIES.
- ALL DIMENSIONS SHOWN ARE TO CENTERLINE OF PIPE UNLESS NOTED OTHERWISE
- ALL WATER MAINS SHALL BE C-900, DR-14 PVC PIPE.
- ALL SANITARY SEWER LINES SHALL BE D-3034, SDR-35 PVC PIPE AT DEPTHS OF LESS THAN 10 FEET. SDR-26 PVC PIPE SHALL BE USED AT DEPTHS OF 10 FEET OF GREATER. SDR-26 PVC PIPE MAY BE USED AT DEPTHS OF LESS THAN 10 FEET.
- THE CONTRACTOR SHALL PROVIDE A TRENCH SAFETY PLAN PRIOR TO BEGINNING HIS WORK.
- ALL SANITARY SEWER LINES AND WATER MAINS SHALL HAVE A MINIMUM COVER OF FORTY-EIGHT INCHES (48") TO THE TOP OF PIPE.
- ALL WATER MAIN FITTINGS SHALL BE MECHANICAL AND SHALL BE POLYWRAPPED.
- PIPE EMBEDMENT AND THRUST BLOCKING SHALL BE PER "CITY OF EULESS STANDARD DETAILS."
- INDIVIDUAL WATER SERVICE AND SANITARY SEWER SERVICE LOCATIONS SHALL BE PERMANENTLY MARKED WITH A STAMP ("W FOR WATER AND "S" FOR SANITARY MINIMUM OF FOUR INCHES (4") IN HEIGHT.
- ALL PROPOSED WATER MAINS SHALL BE PRESSURE TESTED, FLUSHED AND STERILIZED AND MEET ALL FEDERAL AND STATE TESTING REQUIREMENTS.
- ALL FIRE HYDRANTS SHALL BE A TYPE APPROVED BY THE CITY OF EULESS AND SHALL BE INSTALLED AND COLOR-CODED IN ACCORDANCE WITH ALL THE CITY OF EULESS REQUIREMENTS.
- WHERE A SANITARY SEWER SERVICE LINE TIES INTO A MANHOLE, THE SERVICE SHALL BE RAISED ABOVE THE FLOWLINE OF THE MAIN BY SIX INCHES (6") TO ALLOW FOR MAINTENANCE RELATED ISSUES.
- "FLOWABLE FILL" BACKFILL SHALL BE USED FOR ALL MANHOLES UNDER PAVEMENT.

**PAVING AND STORM DRAINAGE GENERAL NOTES**

- THE CONTRACTOR SHALL INSTALL AND MAINTAIN EROSION CONTROL MEASURES IN ACCORDANCE WITH THE DEVELOPMENT PLANS RELEASED FOR CONSTRUCTION. THE CONTRACTOR SHALL INSURE THAT ALL EROSION CONTROL MEASURES ARE MAINTAINED AT ALL TIMES IN A CONDITION ACCEPTABLE TO THE PUBLIC WORKS ENGINEERING INSPECTOR.
- THE CONTRACTOR SHALL NOT STOCKPILE ANY MATERIAL ADJACENT TO ANY CREEK WITHOUT THE WRITTEN AUTHORIZATION OF THE CITY ENGINEER.
- THE CONTRACTOR SHALL NOT ALLOW SOIL AND DEBRIS TO ENTER EXISTING INLETS. ALL INLETS SHALL BE PROTECTED DURING CONSTRUCTION.
- THE CONTRACTOR SHALL NOT DISPOSE OF WASTE OR ANY OTHER MATERIALS INTO STREAMS OR WATERWAYS. EXCESS MATERIAL SHALL BE HAULED OFF-SITE EACH DAY AND WILL NOT BE ALLOWED TO ACCUMULATE.
- THE CONTRACTOR SHALL NOT BURY RUBBISH OR WASTE MATERIALS ON-SITE. BURNING MATERIALS WILL NOT BE ALLOWED WITHOUT PROPER WRITTEN AUTHORIZATION FROM THE EULESS FIRE DEPARTMENT.
- THE CONTRACTOR SHALL WET DOWN THE CONSTRUCTION SITE AS DIRECTED BY THE PUBLIC WORKS ENGINEERING INSPECTOR TO PREVENT BLOWING DUST.
- THE CONTRACTOR SHALL CLEAN STREETS ADJACENT TO THE CONSTRUCTION SITE TO REMOVE MATERIALS DEPOSITED BY CONSTRUCTION VEHICLES ENTERING AND LEAVING THE CONSTRUCTION SITE. THE PUBLIC WORKS ENGINEERING INSPECTOR WILL DETERMINE THE SCHEDULE FOR CLEANING.
- THE CONTRACTOR SHALL BE REQUIRED TO PROVIDE AND MONITOR ALL WARNING AND SAFETY DEVICES (FLASHING LIGHTS, BARRICADES, SIGNS, ETC.) AS DEEMED NECESSARY BY THE CITY OF EULESS. WARNING AND SAFETY DEVICES SHALL CONFORM TO THE TEXAS MANUAL ON UNIFORM TRAFFIC CONTROL DEVICES.
- THE LOCATIONS OF EXISTING UTILITIES SHOWN ON THE PLANS ARE APPROXIMATE. IT SHALL BE THE CONTRACTOR'S RESPONSIBILITY TO LOCATE AND VERIFY IN THE FIELD THE LOCATIONS, ELEVATIONS AND SIZES OF CONFLICTING AND / OR ADJACENT UTILITIES IN ADVANCE OF BEGINNING CONSTRUCTION.
- THE CITY OF EULESS STANDARD DETAILS SHALL SUPERSEDE ANY DETAILS CONTAINED WITHIN THE PLAN SET.
- UNLESS OTHERWISE NOTED, ALL MATERIALS AND CONSTRUCTION SHALL CONFORM TO THE APPLICABLE SPECIFICATIONS AND STANDARDS TO THE CITY OF EULESS AND THE NORTH CENTRAL TEXAS COUNCIL OF GOVERNMENTS - "STANDARD SPECIFICATIONS FOR PUBLIC WORKS CONSTRUCTION" LATEST EDITION.
- CONCRETE FOR STREET PAVEMENT (FIRE LANES) SHALL BE 4200 PSI COMPRESSIVE STRENGTH. FLY ASH WILL NOT BE PERMITTED IN CONCRETE.
- CONCRETE FOR STORM DRAIN INLETS AND STRUCTURES SHALL BE AS SHOWN ON THE PLANS BUT IN NO CASE LESS THAN 3000 PSI COMPRESSIVE STRENGTH.
- ALL STORM SEWER DRAINAGE PIPE SHALL BE CLASS III OR GREATER ASTM C-76 RCP WITH TONGUE AND GROOVE CONNECTIONS.
- ALL BENDS, WYES AND REDUCERS SHALL BE PREFABRICATED BY THE SUPPLIER.
- THE CONTRACTOR SHALL PROVIDE A TRENCH SAFETY PLAN PRIOR TO BEGINNING OF WORK, AND HAVE A COMPETENT PERSON ON SITE AT ALL TIMES. HE SHOULD BE KNOWLEDGEABLE OF SUCH A PLAN AND HAVE THE AUTHORITY TO IMPLEMENT SAME WHERE TRENCHES OVER 5 FEET (5') IN DEPTH ARE ENCOUNTERED.
- ALL STORM SEWER PIPE JOINTS SHALL USE OMNI-FLEX JOINT SEALER OR AN APPROVED EQUAL.

no.	revision	by	date

ICIVIL ENGINEERING  
 202 REPUBLIC LN  
 EULESS, TX 76040  
 PH: (972) 523-5493  
 TBPE: F-19293

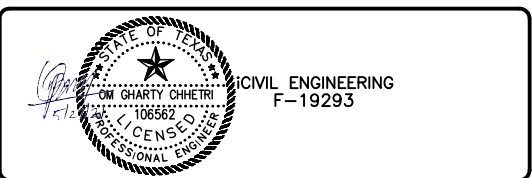

scale  
 horiz  
 N/A  
 vert  
 N/A  
 date  
 MAY 2021



GENERAL NOTES  
**NEPALI CULTURAL AND SPIRITUAL CENTER  
 PHASE-I**  
 1212 ROYAL PARKWAY, EULESS TEXAS 76040

PROJECT NO.  
 JN 1120  
 sheet  
 2  
 of  
 23

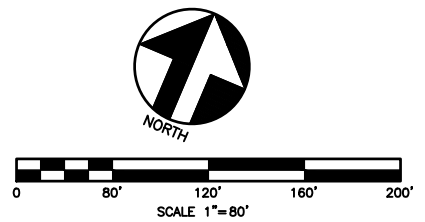
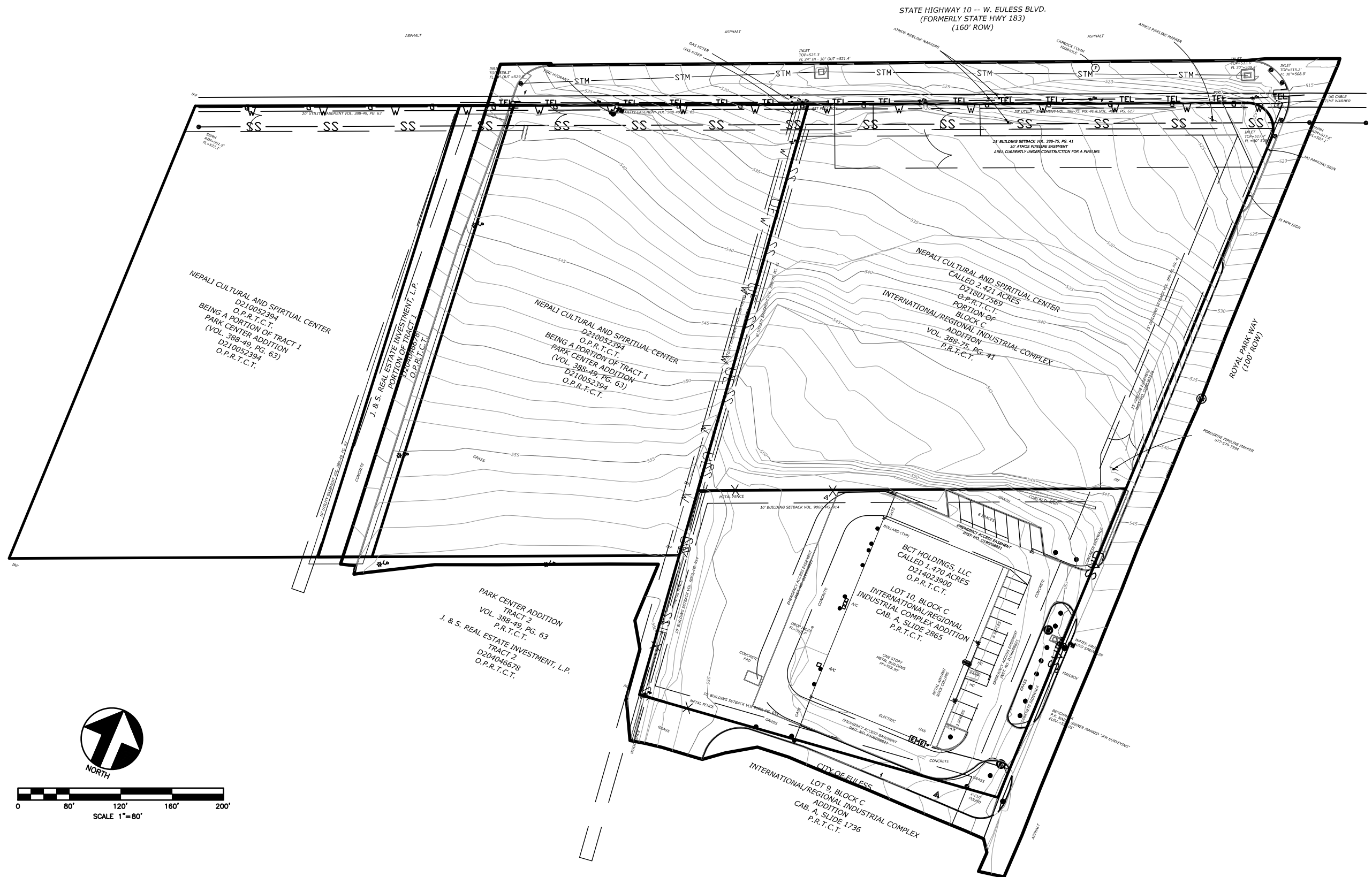

no.	revision	by	date

CIVIL ENGINEERING  
 202 REPUBLIC LN  
 EULESS, TX 76040  
 PH: (972) 523-5493  
 TBPE: F-19293

CIVIL ENGINEERING  
 F-19293

scale  
 horiz  
 N/A  
 vert  
 N/A  
 date  
 MAY 2021



**FOR REFERENCE ONLY**

EXISTING SURVEY  
**NEPALI CULTURAL AND SPIRITUAL CENTER  
 PHASE-I**  
 1212 ROYAL PARKWAY, EULESS TEXAS 76040

PROJECT NO.  
 JN 1120  
 sheet  
 3  
 of  
 23

**HIGHWAY DESIGNATION: S.H.-10**

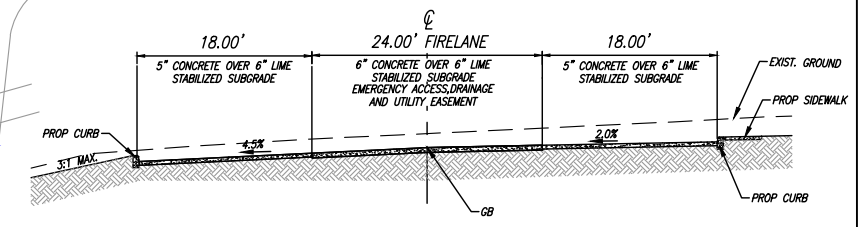
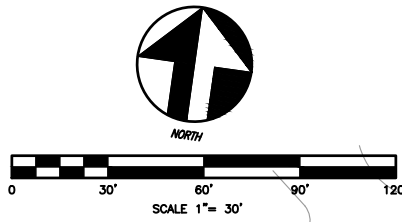

**TYPICAL DRIVEWAY SECTION**  
NOT TO SCALE

**LANDSCAPING CALCULATIONS**

STREETYARD: 181,533 S.F.  
LANDSCAPING: 153,069 S.F.

**TOTAL PARKING: 189 COMBINED**  
**TEMPLE PARKING: 130**  
STANDARD: 118  
HANDICAP: 12  
**COMMUNITY CENTER PARKING: 59**  
STANDARD: 55  
HANDICAP: 4

**LEGEND**

- 6" CONCRETE PAVEMENT (MIN. 4200 PSI COMPRESSIVE), #4 BARS @ 18" CENTERS EACH WAY OVER 6" COMPACTED SUBGRADE
- 5" CONCRETE PAVEMENT (MIN. 3500 PSI COMPRESSIVE, 500 PSI FLEXURAL), #3 BARS @ 18" CENTERS EACH WAY OVER 6" COMPACTED SUBGRADE.
- 4" CONCRETE PAVEMENT (MIN. 3000 PSI) OVER 2" COMPACTED SAND BEDDING
- EXISTING DRIVEWAY
- PHASE II CONSTRUCTION

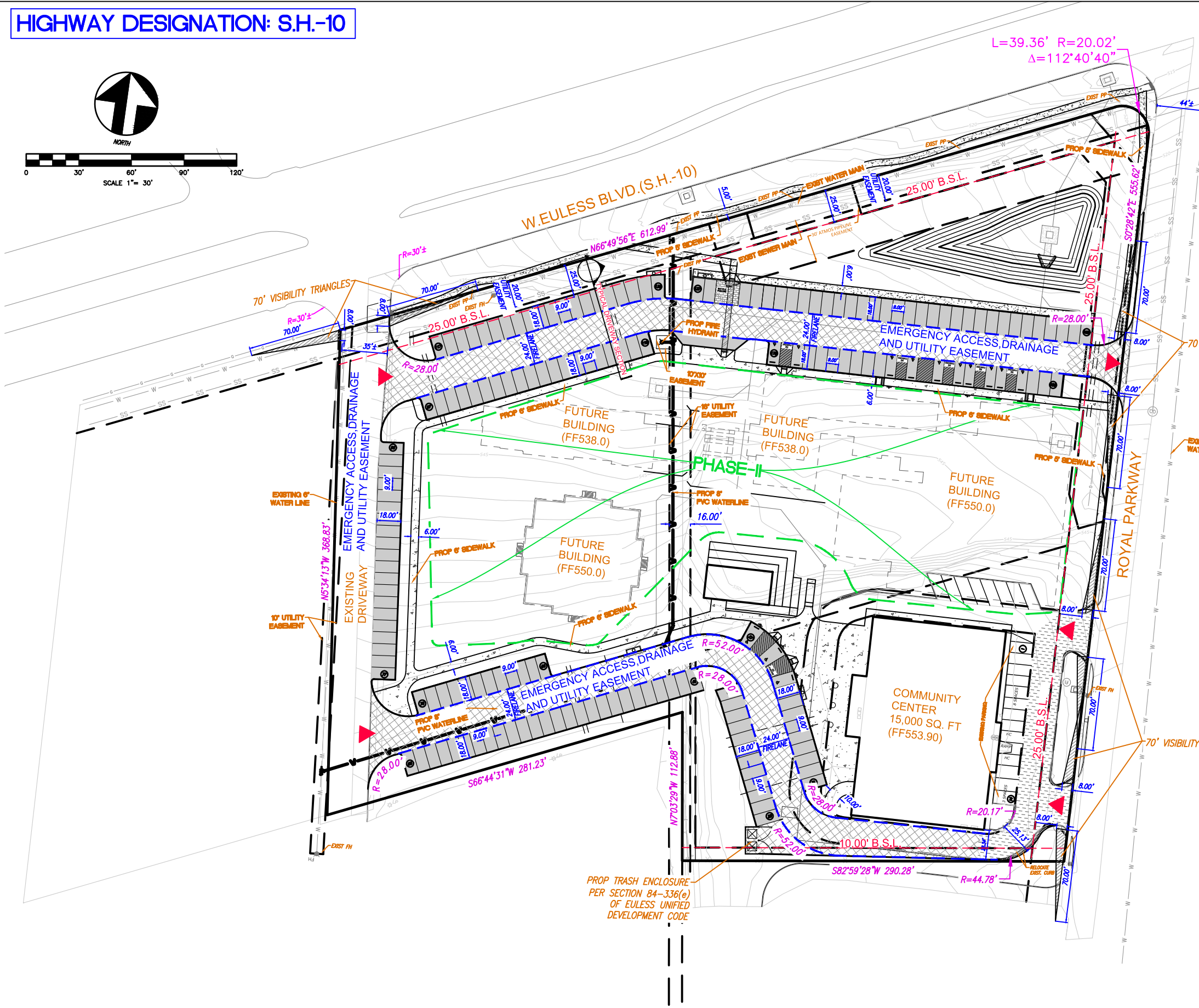

PREPARATION DATE: 28 May 2021

no.	revision	by	date

iCIVIL ENGINEERING  
202 REPUBLIC LN  
EULESS, TX 76040  
PH: (972) 523-5493  
  
TBPE: F-19293

scale  
horiz  
N/A  
vert  
N/A  
date  
MAY 2021



**FOR REFERENCE ONLY**

SITE PLAN  
NEPALI CULTURAL AND SPIRITUAL CENTER  
PHASE-I  
1212 ROYAL PARKWAY, EULESS TEXAS 76040

PROJECT NO.  
JN 1120  
sheet  
4  
of  
23

**HIGHWAY DESIGNATION: S.H.-10**

**W. EULESS BLVD(HWY 10).**

$N66^{\circ}49'56''E$  612.99'

$L=39.36'$   $R=20.02'$   
 $\Delta=112^{\circ}40'40''$

EXISTING SIGN  
PROTECT IN PLACE

EXISTING SIGN  
PROTECT IN PLACE

EXISTING SIGN  
PROTECT IN PLACE

EXISTING UTILITY EASEMENT

$N5^{\circ}34'13''W$  368.83'  
EXIST DRIVENWAY



REMOVE EXISTING  
CURB

EXISTING SIGN  
PROTECT IN PLACE

REMOVE EXISTING  
METAL FENCE

ROYAL PARKWAY  
 $S0^{\circ}28'42''E$  555.62'

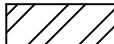
**LEGEND**

-  REMOVE EXISTING CONCRETE
-  REMOVE EXISTING FENCE
-  REMOVE EXISTING CURB

$S66^{\circ}44'31''W$  281.23'

REMOVE EXISTING  
CONCRETE

EXIST BUILDING  
(FF-553.90)

PROTECT EXISTING  
METAL FENCE

PROTECT EXISTING  
METAL FENCE

$S82^{\circ}59'28''W$  290.28'

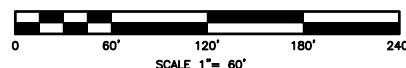

no.	revision	by	date

CIVIL ENGINEERING  
202 REPUBLIC LN  
EULESS, TX 76040  
PH: (972) 523-5493  
  
TBPE: F-19293

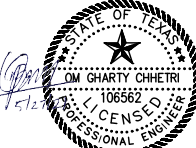

CIVIL ENGINEERING  
F-19293

scale  
horiz  
N/A  
vert  
N/A  
date  
MAY 2021



**DEMOLITION PLAN**  
**NEPALI CULTURAL AND SPIRITUAL CENTER**  
**PHASE-I**  
1212 ROYAL PARKWAY, EULESS TEXAS 76040

PROJECT NO.  
JN 1120  
sheet  
5  
of  
23

HIGHWAY DESIGNATION SH-10

W. EULESS BLVD(HWY10)

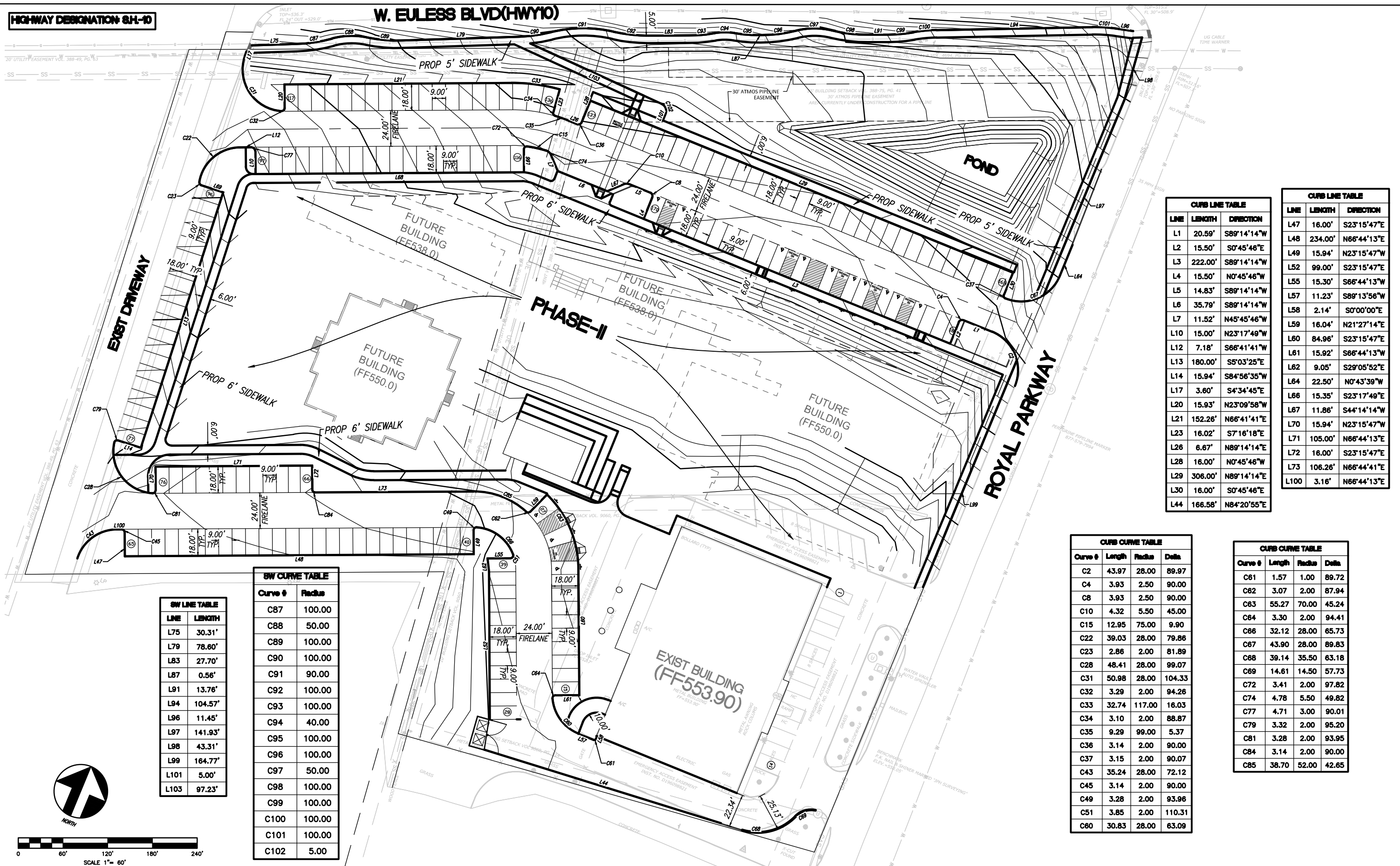

**CURB LINE TABLE**

LINE	LENGTH	DIRECTION
L1	20.59'	S89°14'14"W
L2	15.50'	S0°45'46"E
L3	222.00'	S89°14'14"W
L4	15.50'	N0°45'46"W
L5	14.83'	S89°14'14"W
L6	35.79'	S89°14'14"W
L7	11.52'	N45°45'46"W
L10	15.00'	N23°17'49"W
L12	7.18'	S66°41'41"W
L13	180.00'	S5°03'25"E
L14	15.94'	S84°56'35"W
L17	3.60'	S4°34'45"E
L20	15.93'	N23°09'58"W
L21	152.26'	N66°41'41"E
L23	16.02'	S7°16'18"E
L26	6.67'	N89°14'14"E
L28	16.00'	N0°45'46"W
L29	306.00'	N89°14'14"E
L30	16.00'	S0°45'46"E
L44	166.58'	N84°20'55"E

**CURB LINE TABLE**

LINE	LENGTH	DIRECTION
L47	16.00'	S23°15'47"E
L48	234.00'	N66°44'13"E
L49	15.94'	N23°15'47"W
L52	99.00'	S23°15'47"E
L55	15.30'	S66°44'13"W
L57	11.23'	S89°13'56"W
L58	2.14'	S0°00'00"E
L59	16.04'	N21°27'14"E
L60	84.96'	S23°15'47"E
L61	15.92'	S66°44'13"W
L62	9.05'	S29°05'52"E
L64	22.50'	N0°43'39"W
L66	15.35'	S23°17'49"E
L67	11.86'	S44°14'14"W
L70	15.94'	N23°15'47"W
L71	105.00'	N66°44'13"E
L72	16.00'	S23°15'47"E
L73	106.26'	N66°44'41"E
L100	3.16'	N66°44'13"E

**CURB CURVE TABLE**

Curve #	Length	Radius	Delta
C2	43.97	28.00	89.97
C4	3.93	2.50	90.00
C8	3.93	2.50	90.00
C10	4.32	5.50	45.00
C15	12.95	75.00	9.90
C22	39.03	28.00	79.86
C23	2.86	2.00	81.89
C28	48.41	28.00	99.07
C31	50.98	28.00	104.33
C32	3.29	2.00	94.26
C33	32.74	117.00	16.03
C34	3.10	2.00	88.87
C35	9.29	99.00	5.37
C36	3.14	2.00	90.00
C37	3.15	2.00	90.07
C43	35.24	28.00	72.12
C45	3.14	2.00	90.00
C49	3.28	2.00	93.96
C51	3.85	2.00	110.31
C60	30.83	28.00	63.09

**CURB CURVE TABLE**

Curve #	Length	Radius	Delta
C61	1.57	1.00	89.72
C62	3.07	2.00	87.94
C63	55.27	70.00	45.24
C64	3.30	2.00	94.41
C66	32.12	28.00	65.73
C67	43.90	28.00	89.83
C68	39.14	35.50	63.18
C69	14.61	14.50	57.73
C72	3.41	2.00	97.82
C74	4.78	5.50	49.82
C77	4.71	3.00	90.01
C79	3.32	2.00	95.20
C81	3.28	2.00	93.95
C84	3.14	2.00	90.00
C85	38.70	52.00	42.65

**SW CURVE TABLE**

Curve #	Radius
C87	100.00
C88	50.00
C89	100.00
C90	100.00
C91	90.00
C92	100.00
C93	100.00
C94	40.00
C95	100.00
C96	100.00
C97	50.00
C98	100.00
C99	100.00
C100	100.00
C101	100.00
C102	5.00

**SW LINE TABLE**

LINE	LENGTH
L75	30.31'
L79	78.60'
L83	27.70'
L87	0.56'
L91	13.76'
L94	104.57'
L96	11.45'
L97	141.93'
L98	43.31'
L99	164.77'
L101	5.00'
L103	97.23'

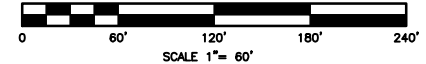

no.	revision	by	date

ICIVIL ENGINEERING  
202 REPUBLIC LN  
EULESS, TX 76040  
PH: (972) 523-5493  
  
TBPE: F-19293

ICIVIL ENGINEERING  
F-19293

scale  
horiz  
N/A  
vert  
N/A  
date  
MAY 2021



PRELIMINARY PLAN  
For Review Only  
This document is released for the purpose of interim review and markup under the authority of OM GHARTY CHHETRI, P.E. License No: 106562 on 5/28/21. This document is not to be used for construction, bidding or permit purposes.

**HORIZONTAL CONTROL PLAN**  
  
NEPALI CULTURAL AND SPIRITUAL CENTER  
PHASE-I  
1212 ROYAL PARKWAY, EULESS TEXAS 76040

PROJECT NO.  
JN 1120  
sheet  
6  
of  
23

**HIGHWAY DESIGNATION: S.H.-10**

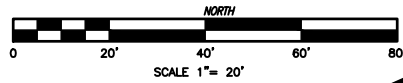
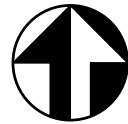

**W. EULESS BLVD.(S.H.-10)**

**SEE DETAIL-A**

**CONSTRUCTION NOTE**

- 1 CONSTRUCT 6" CURB MONOLITHIC TO PAVEMENT
- 2 CONSTRUCT 6" CONCRETE PAVEMENT OVER 6" LIME STABILIZED SUBGRADE AND PER GEOTECHNICAL REPORT
- 3 CONSTRUCT 5" CONCRETE PAVEMENT OVER 6" LIME STABILIZED SUBGRADE AND PER GEOTECHNICAL REPORT
- 4 CONSTRUCT TRASH ENCLOSURE
- 5 CONSTRUCT RAMP PER PED-18 DETAILS
- 6 CONSTRUCT SIDEWALK (WIDTH PER PLAN) PER CITY OF EULESS STD DWG NO. COE-SW
- 7 INSTALL ACCESSIBLE PARKING SPACE SIGNAGE AND SURFACE IDENTIFICATION MARKINGS
- 8 CONSTRUCT CONCRETE HEADWALL
- 9 PAINT 9' LONG BY 4" ANGLED WIDE YELLOW LINES AT 30" ON CENTER

**DETAIL-A**

**W. EULESS BLVD.(S.H.-10)**

**POND**

**ROYAL PARKWAY**

**NOTE: WORK IN TXDOT ROW REQUIRES TXDOT PERMIT**

**NOTE: SIDEWALK ALONG ROYAL PARKWAY IS ADA NON-COMPLIANT ON SLOPE. SIDEWALK FOLLOWS STREET GRADE (VARIES 5-12%)**

**MATCHLINE SEE SHEET-8**

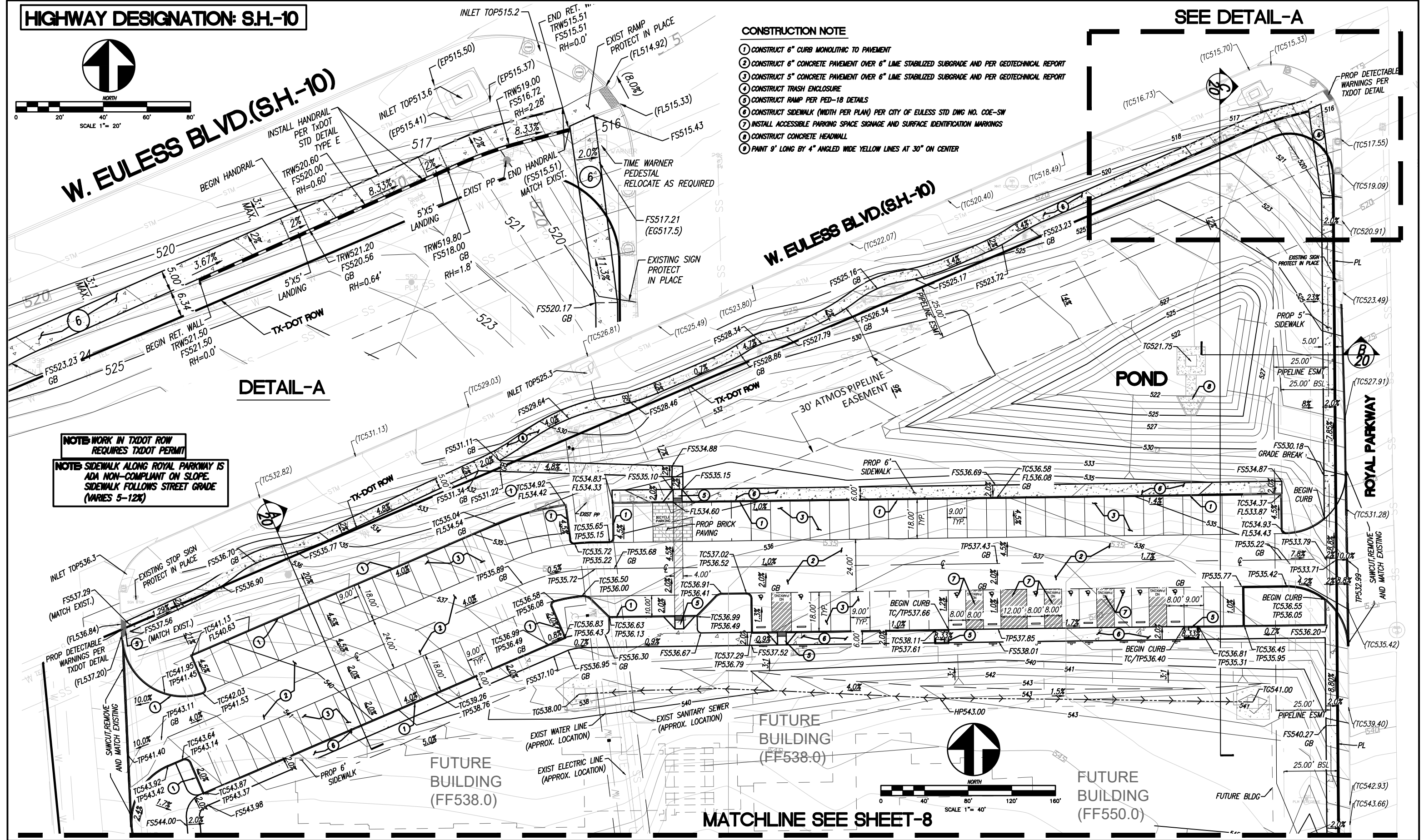
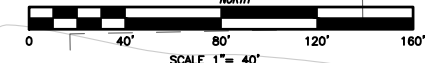

no.	revision	by	date

iCIVIL ENGINEERING  
202 REPUBLIC LN  
EULESS, TX 76040  
PH: (972) 523-5493

TBPE: F-19293

iCIVIL ENGINEERING  
F-19293

scale  
horiz N/A  
vert N/A  
date  
MAY 2021



GRADING PLANS

**NEPALI CULTURAL AND SPIRITUAL CENTER  
PHASE-1**

1212 ROYAL PARKWAY, EULESS TEXAS 76040

PROJECT NO.  
JN 1120

sheet  
7  
of  
23

MATCHLINE SEE SHEET-7

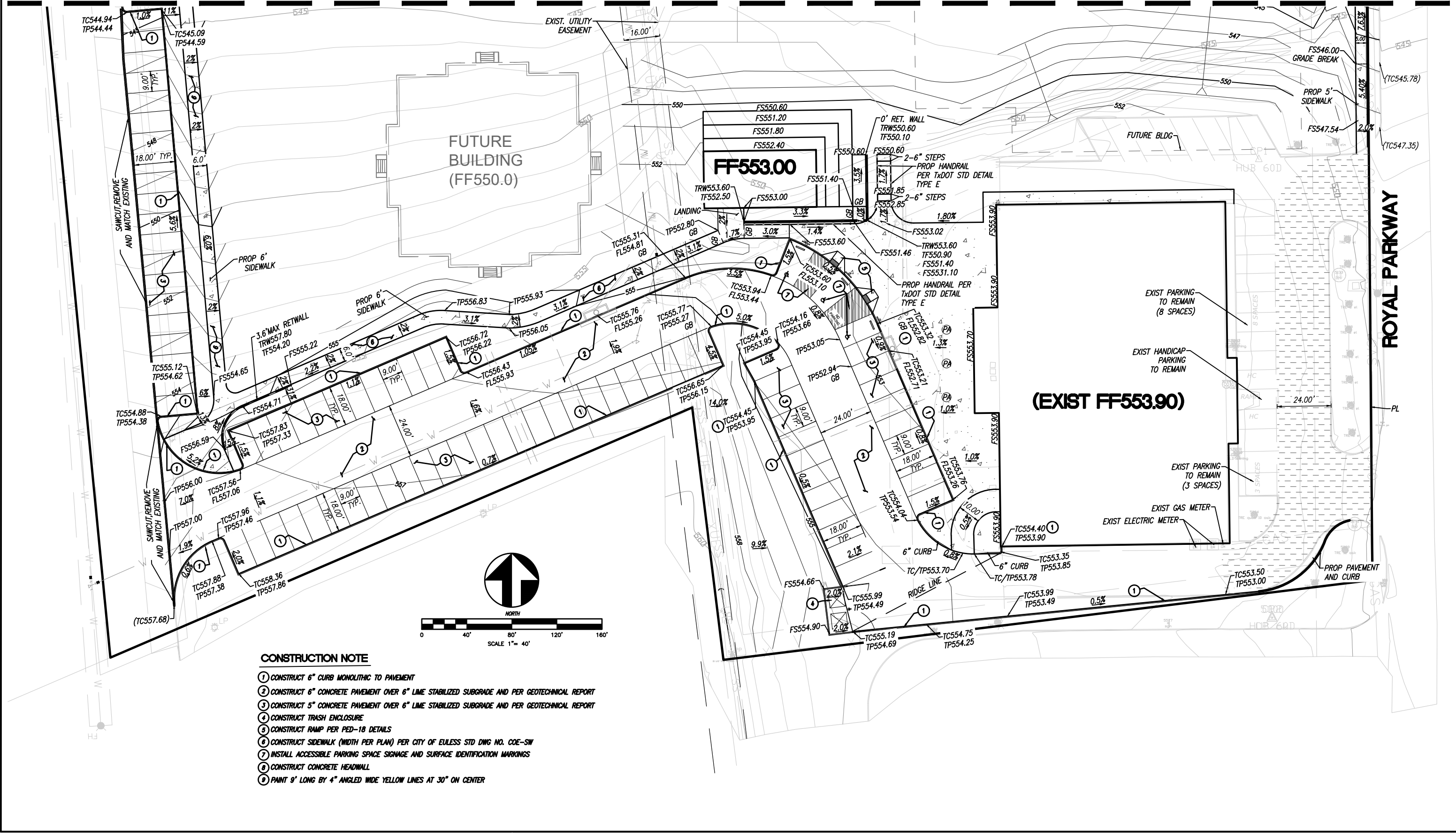

**CONSTRUCTION NOTE**

- ① CONSTRUCT 6" CURB MONOLITHIC TO PAVEMENT
- ② CONSTRUCT 6" CONCRETE PAVEMENT OVER 6" LIME STABILIZED SUBGRADE AND PER GEOTECHNICAL REPORT
- ③ CONSTRUCT 5" CONCRETE PAVEMENT OVER 6" LIME STABILIZED SUBGRADE AND PER GEOTECHNICAL REPORT
- ④ CONSTRUCT TRASH ENCLOSURE
- ⑤ CONSTRUCT RAMP PER PED-18 DETAILS
- ⑥ CONSTRUCT SIDEWALK (WIDTH PER PLAN) PER CITY OF EULESS STD DWG NO. COE-SW
- ⑦ INSTALL ACCESSIBLE PARKING SPACE SIGNAGE AND SURFACE IDENTIFICATION MARKINGS
- ⑧ CONSTRUCT CONCRETE HEADWALL
- ⑨ PAINT 9' LONG BY 4" ANGLED WIDE YELLOW LINES AT 30° ON CENTER

no.	revision	by	date

iCIVIL ENGINEERING  
 202 REPUBLIC LN  
 EULESS, TX 76040  
 PH: (972) 523-5493  
 TBPE: F-19293

iCIVIL ENGINEERING  
 F-19293

scale  
 horiz N/A  
 vert N/A  
 date  
 MAY 2021



GRADING PLANS

**NEPALI CULTURAL AND SPIRITUAL CENTER  
 PHASE-I**  
 1212 ROYAL PARKWAY, EULESS TEXAS 76040

PROJECT NO.  
 JN 1120  
 sheet  
 8  
 of  
 23



**HIGHWAY DESIGNATION: S.H.-10**

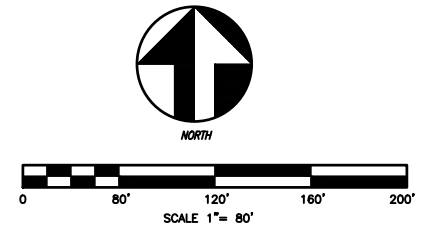
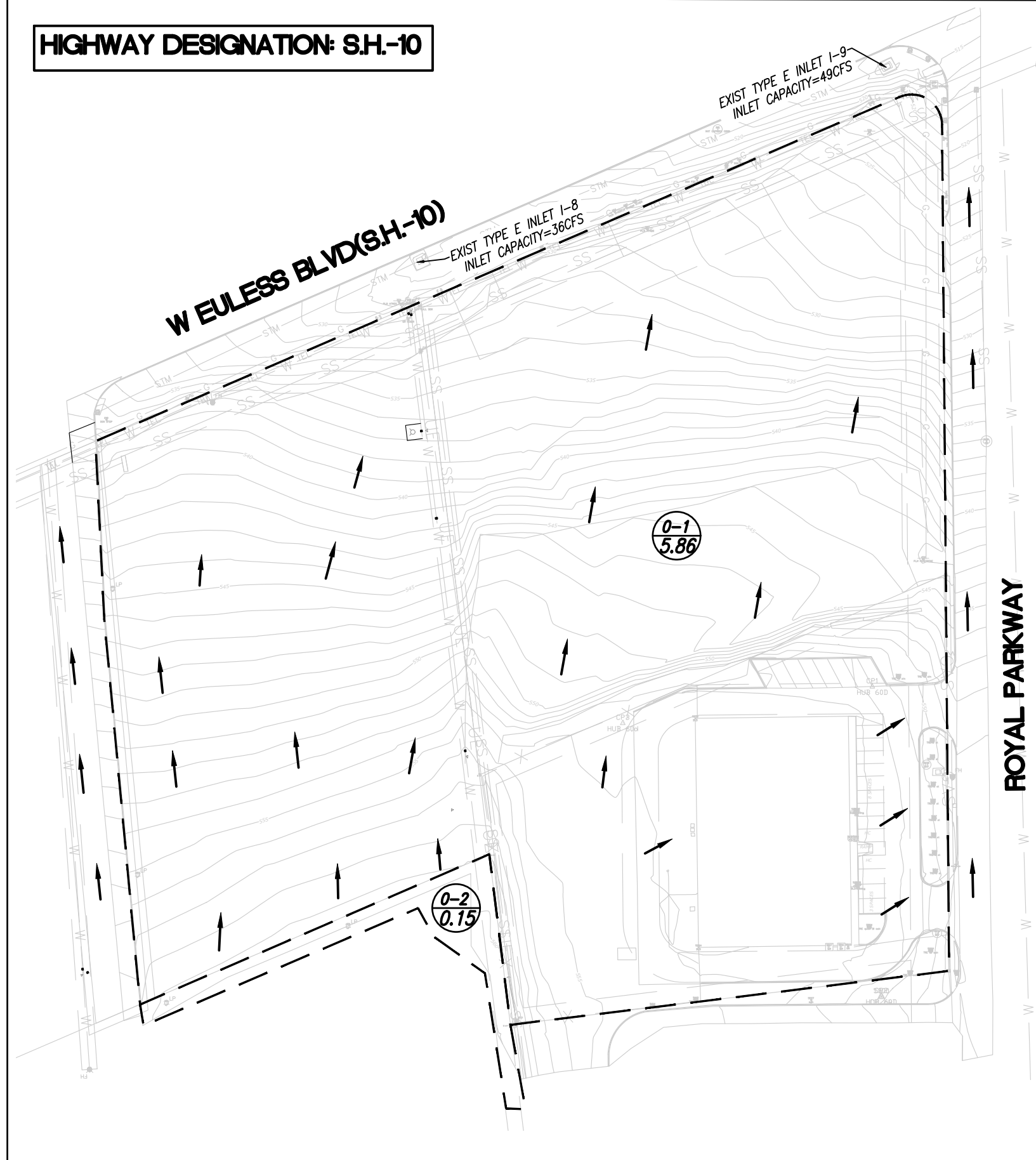

**Q=CIA**

WHERE,  
 C=RUNOFF COEFFICIENT  
 I=RAINFALL INTENSITY  
 A=DRAINAGE AREA

**RUNOFF CALCULATION**

**PRE DEVELOPMENT**

ID	AREA (ACRE)	RUNOFF COEFFICIENT	CONCENTRATION TIME (MIN)	INTENSITY (IN/HR)				RUNOFF (CFS)				REMARKS
				5 YRS	10 YRS	25 YRS	100 YRS	5 YRS	10 YRS	25 YRS	100 YRS	
0-1	5.855	0.30	15	5.5	6.6	7.8	9.8	9.67	11.59	13.70	17.23	DRAINS TO EXISTING DROP INLETS AT HWY 10
0-2	0.152	0.30	15	5.5	6.6	7.8	9.8	0.25	0.30	0.36	0.44	DRAINS TO SUBJECT PROPERTY AND TO EXISTING INLETS AT HWY10

NOTE- CURRENT TXDOT STORM DRAIN SYSTEM ARE DESIGNED TO CONVEY DEVELOPED Q5 RUNOFF FROM PROJECT SITE. REFER TXDOT PROJECT NO. CCSJ-0094-02-074.

**LEGEND**

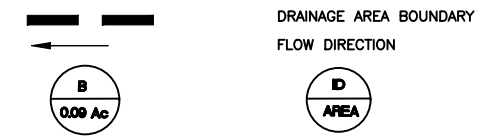

no.	revision	by	date

CIVIL ENGINEERING  
 202 REPUBLIC LN  
 EULESS, TX 76040  
 PH: (972) 523-5493  
 TBPE: F-19293

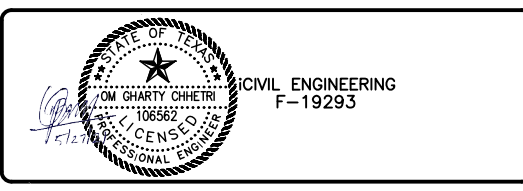

scale  
 horiz  
 N/A  
 vert  
 N/A  
 date  
 MAY 2021

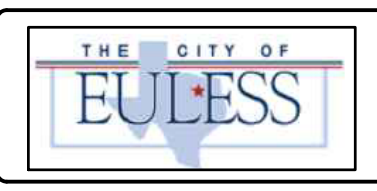

EXISTING CONDITION DRAINAGE AREA MAP  
**NEPALI CULTURAL AND SPIRITUAL CENTER**  
**PHASE-I**  
 1212 ROYAL PARKWAY, EULESS TEXAS 76040

PROJECT NO.  
 JN 1120  
 sheet  
 9  
 of  
 23

**HIGHWAY DESIGNATION: S.H.-10**

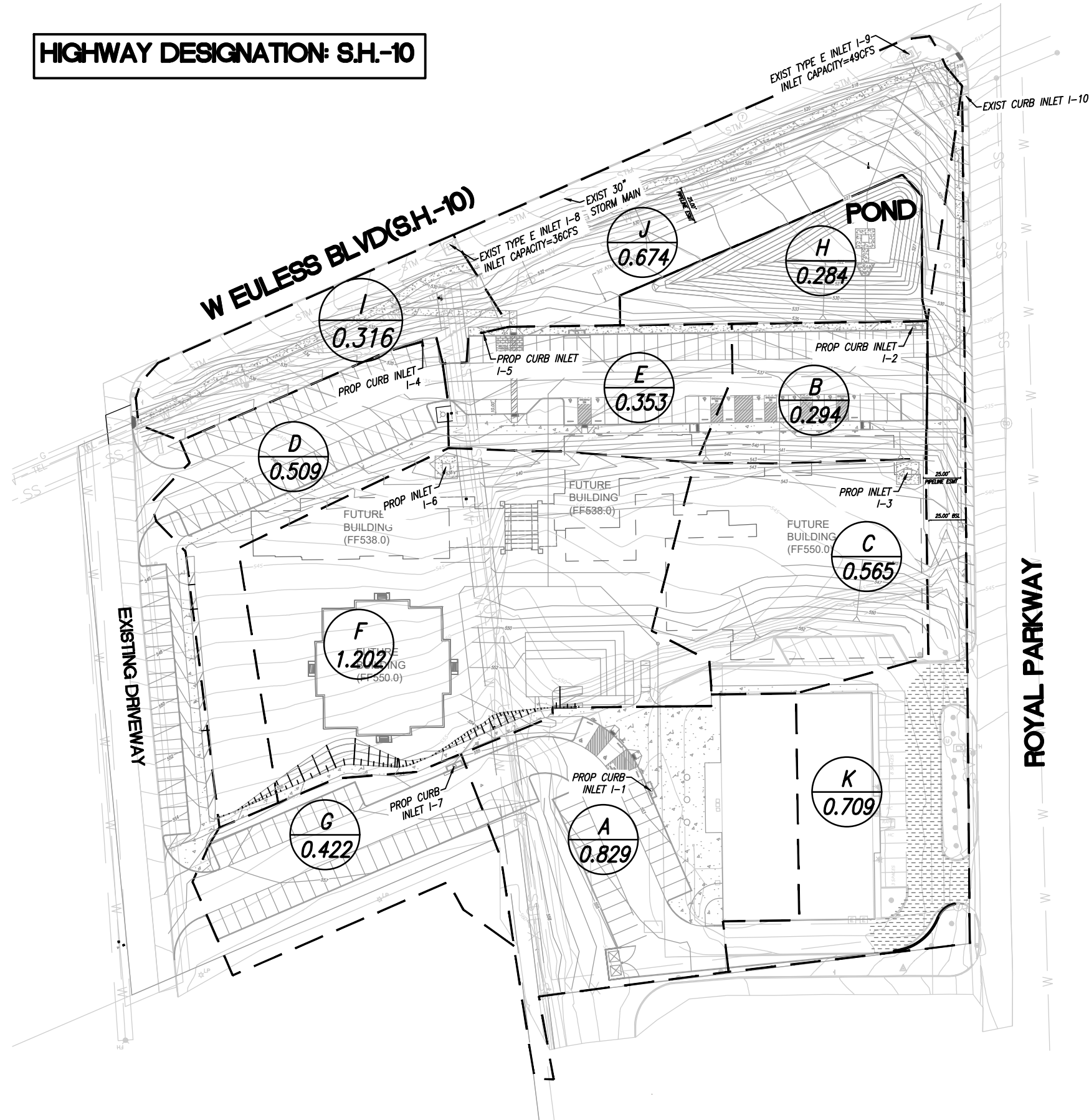
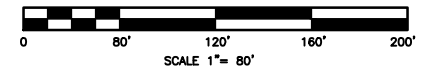

**Q=CIA**  
 WHERE:  
 C=RUNOFF COEFFICIENT  
 I=RAINFALL INTENSITY  
 A=DRAINAGE AREA

**RUNOFF CALCULATION**

**POST DEVELOPMENT**

ID	AREA (ACRE)	RUNOFF COEFFICIENT	CONCENTRATION TIME (MIN)	INTENSITY (IN/HR)				RUNOFF (CFS)				REMARKS
				5 YRS	10 YRS	25 YRS	100 YRS	5 YRS	10 YRS	25 YRS	100 YRS	
A	0.829	0.90	10	6.6	7.8	9.3	11.9	4.92	5.82	6.95	8.88	DRAINS TO INLET I-1 & TO POND
B	0.294	0.90	10	6.6	7.8	9.3	11.9	1.75	2.06	2.46	3.15	DRAINS TO INLET I-2 & TO POND
C	0.565	0.90	10	6.6	7.8	9.3	11.9	3.35	3.98	4.74	6.05	DRAINS TO INLET I-3 & TO POND
D	0.509	0.90	10	6.6	7.8	9.3	11.9	3.02	3.57	4.26	5.45	DRAINS TO INLET I-4 & TO POND
E	0.353	0.90	10	6.6	7.8	9.3	11.9	2.10	2.49	2.97	3.78	DRAINS TO INLET I-5 & TO POND
F	1.202	0.90	10	6.6	7.8	9.3	11.9	7.14	8.42	10.04	12.87	DRAINS TO INLET I-6 & TO POND
G	0.422	0.90	10	6.6	7.8	9.3	11.9	2.50	2.96	3.53	4.52	DRAINS TO INLET I-7 & TO POND
H	0.284	0.90	10	6.6	7.8	9.3	11.9	1.69	2.00	2.38	3.04	DRAINS TO DETENTION POND
I	0.316	0.90	10	6.6	7.8	9.3	11.9	1.88	2.21	2.64	3.38	DRAINS TO EXIST INLET I-8 CAPACITY-36 CFS, PER TXDOT PLANS(SHEET 80) *
J	0.674	0.90	10	6.6	7.8	9.3	11.9	4.00	4.73	5.65	7.21	DRAINS TO EXIST INLET I-9 CAPACITY-49 CFS, PER TXDOT PLANS(SHEET 80) *
K	0.709	0.90	10	6.6	7.8	9.3	11.9	4.21	4.98	5.93	7.59	DRAINS TO EXIST INLET I-10

**POND SUMMARY**

AREA (ACRE)	PEAK RUNOFF (INFLOW) (CFS)				PEAK RUNOFF (OUTFLOW) (CFS)				REMARKS
	5 YRS	10 YRS	25 YRS	100 YRS	5 YRS	10 YRS	25 YRS	100 YRS	
4.46	26.47	32.48	37.33	47.74	15.98	18.09	19.70	22.32	AREA A-G DRAINS TO POND, ALLOWABLE PEAK RELEASE RATE (Q5)=26.47 < 22.32 (ACTUAL)

\*NOTE- CURRENT TXDOT STORM DRAIN SYSTEM ARE DESIGNED TO CONVEY DEVELOPED Q5 RUNOFF FROM PROJECT SITE. REFER TXDOT PROJECT NO. CCSJ-0094-02-074.

**LEGEND**

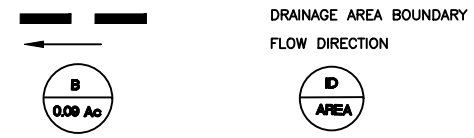

no.	revision	by	date

**iCIVIL ENGINEERING**  
 202 REPUBLIC LN  
 EULESS, TX 76040  
 PH: (972) 523-5493  
 TBPE: F-19293

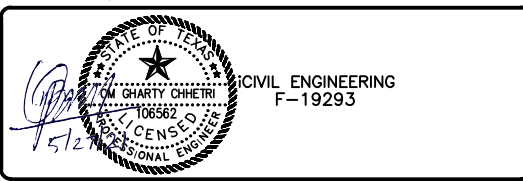

scale  
 horiz N/A  
 vert N/A  
 date  
 MAY 2021



PROPOSED CONDITION DRAINAGE AREA MAP  
**NEPALI CULTURAL AND SPIRITUAL CENTER**  
 PHASE-I  
 1212 ROYAL PARKWAY, EULESS TEXAS 76040

PROJECT NO.  
 JN 1120  
 sheet  
 10  
 of  
 23

**HIGHWAY DESIGNATION: S.H.-10**

**W. EULESS BLVD.(S.H.-10)**

**EMBEDMENT FOR RCP PIPE PER CITY OF EULESS STD DETAIL 3020A**

LOCATIONS OF EXISTING UTILITIES ARE APPROXIMATE AND ARE BASED ON PUBLIC RECORDS. THE CONTRACTOR IS COMPLETELY RESPONSIBLE FOR LOCATING ALL EXISTING UTILITIES, BOTH HORIZONTALLY AND VERTICALLY BEFORE THE COMMENCEMENT OF ANY CONSTRUCTION. IF ANY EXISTING UTILITY POLES, POWER POLES, GUY WIRES, TELEPHONE/CABLE UTILITIES, GAS UTILITIES OR ANY UNDERGROUND STRUCTURE ETC. ARE FOUND TO BE IN CONFLICT WITH THESE CONSTRUCTION PLANS, THE CONTRACTOR SHALL CONTACT THE APPROPRIATE UTILITY COMPANY AND COORDINATE THE RELOCATION OF ANY AND/OR ALL SUCH UTILITIES (NO SPECIAL PAY) AND NOTIFY THE ENGINEER OF RECORD IN WRITING.

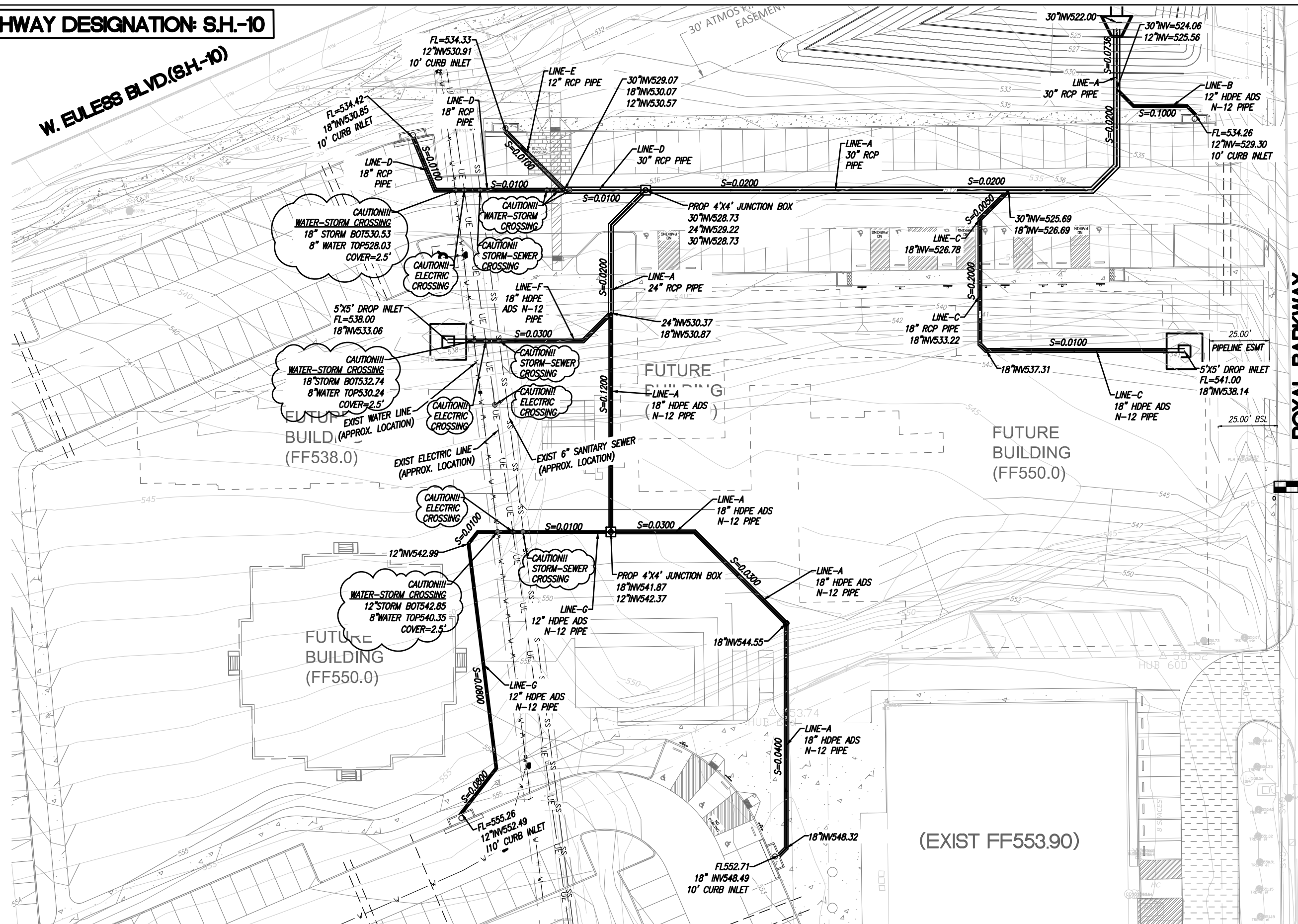

**ROYAL PARKWAY**

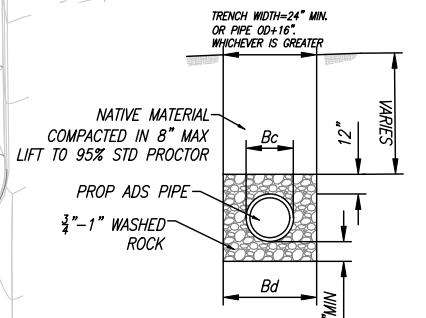
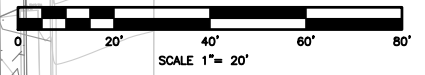

**NOTES:**  
 1. Bc=OUTSIDE DIAMETER OF PIPE  
 2. Bd=TRENCH WIDTH

**ADS PIPE EMBEDMENT DETAIL**  
 NOT TO SCALE

no.	revision	by	date

iCIVIL ENGINEERING  
 202 REPUBLIC LN  
 EULESS, TX 76040  
 PH: (972) 523-5493  
 TBPE: F-19293

iCIVIL ENGINEERING  
 F-19293

scale  
 horiz N/A  
 vert N/A  
 date  
 MAY 2021



(EXIST FF553.90)

STORMDRAIN PLAN  
**NEPALI CULTURAL AND SPIRITUAL CENTER**  
 PHASE-I  
 1212 ROYAL PARKWAY, EULESS TEXAS 76040

PROJECT NO.  
 JN 1120  
 sheet  
 11  
 of  
 23

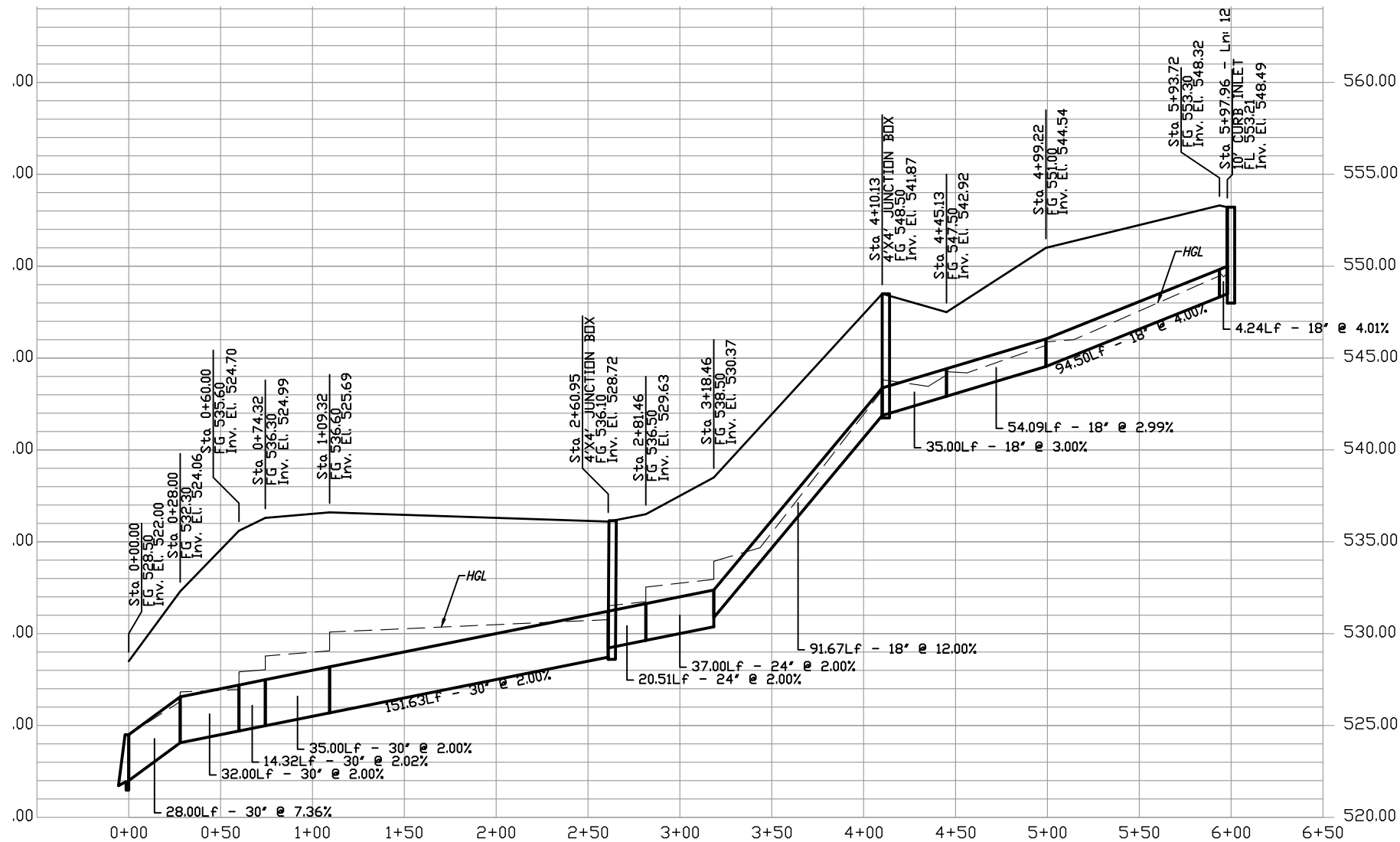

LINE-A PROFILE

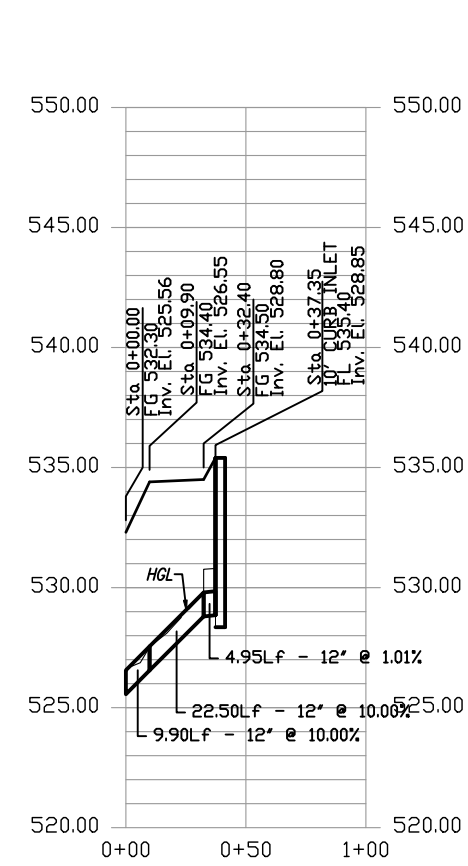

LINE-B PROFILE

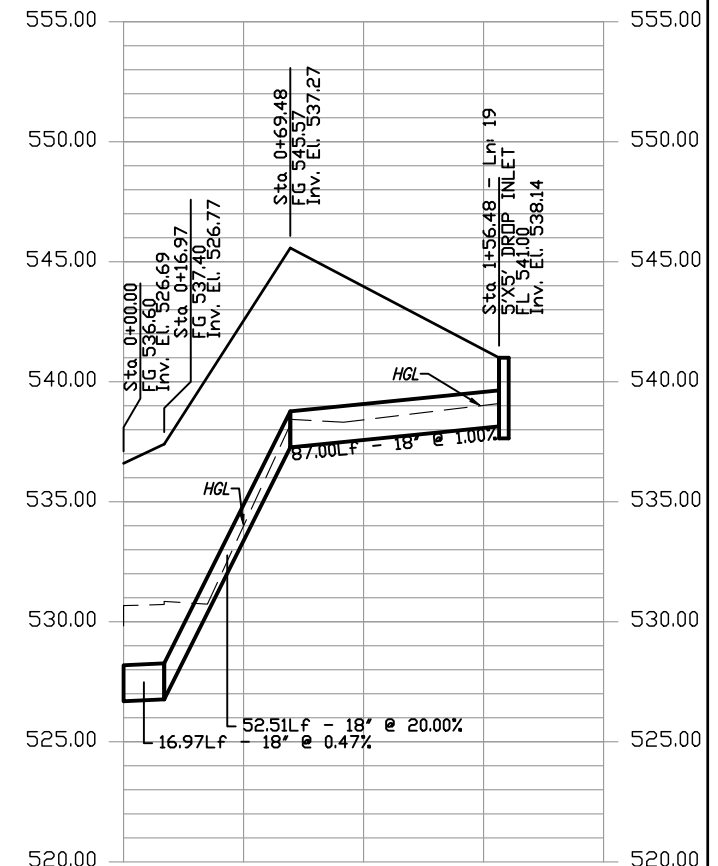

LINE-C PROFILE

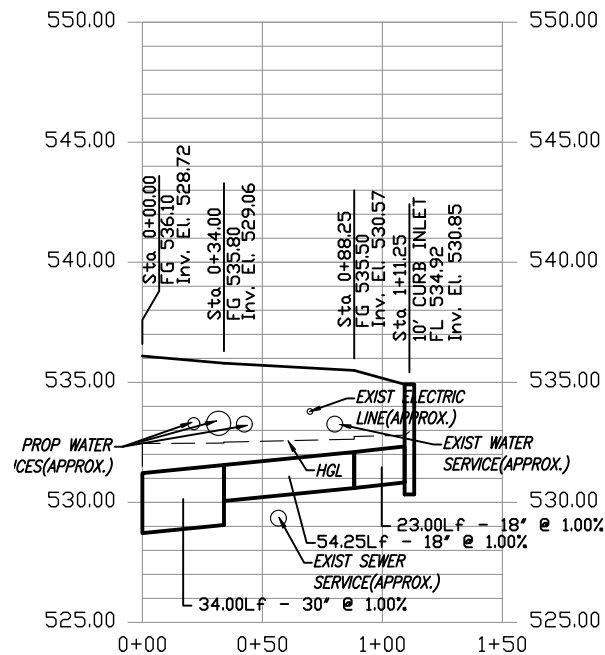

LINE-D PROFILE

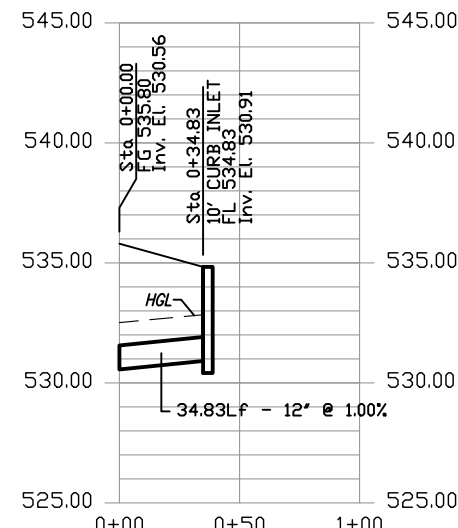

LINE-E PROFILE

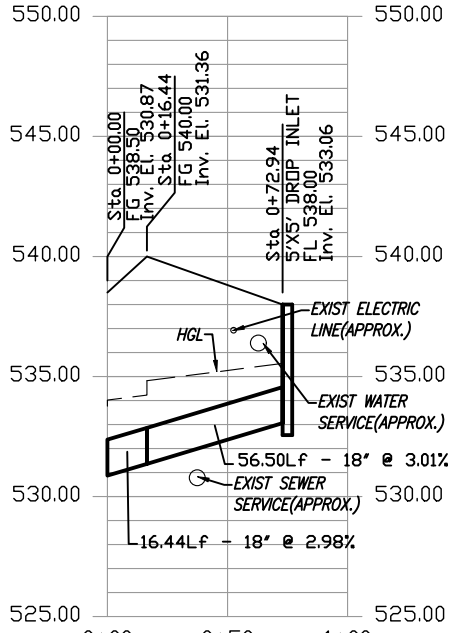

LINE-F PROFILE

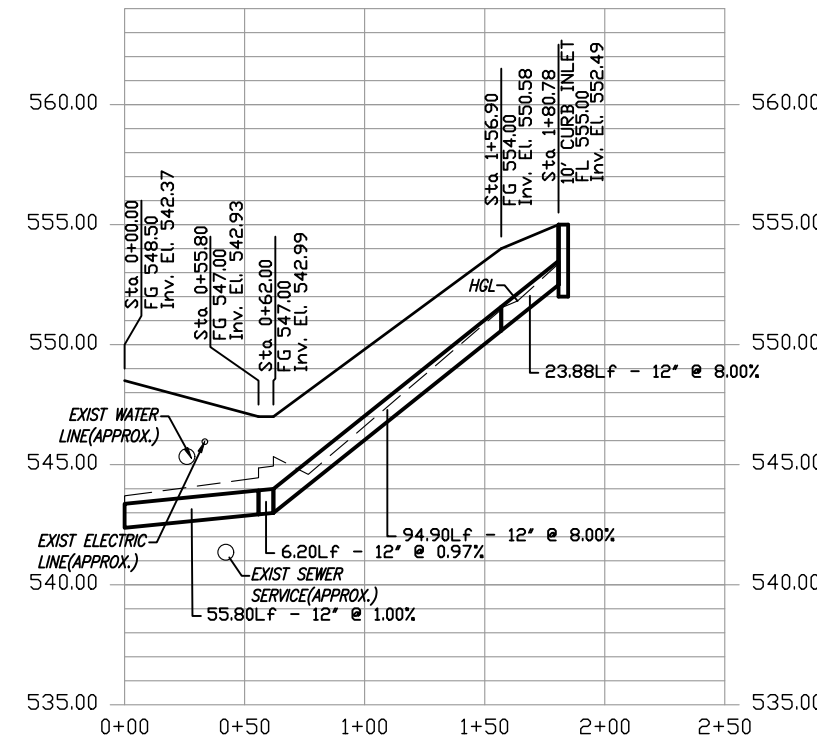

LINE-G PROFILE

HORIZONTAL SCALE: 1"=40'  
VERTICAL SCALE: 1"=4'

LOCATIONS OF EXISTING UTILITIES ARE APPROXIMATE AND ARE BASED ON PUBLIC RECORDS. THE CONTRACTOR IS COMPLETELY RESPONSIBLE FOR LOCATING ALL EXISTING UTILITIES, BOTH HORIZONTALLY AND VERTICALLY BEFORE THE COMMENCEMENT OF ANY CONSTRUCTION. IF ANY EXISTING UTILITY POLES, POWER POLES, GUY WIRES, TELEPHONE/CABLE UTILITIES, GAS UTILITIES OR ANY UNDERGROUND STRUCTURE ETC. ARE FOUND TO BE IN CONFLICT WITH THESE CONSTRUCTION PLANS, THE CONTRACTOR SHALL CONTACT THE APPROPRIATE UTILITY COMPANY AND COORDINATE THE RELOCATION OF ANY AND/OR ALL SUCH UTILITIES (AND SPECIAL PAY) AND NOTIFY THE ENGINEER OF RECORD IN WRITING.

no.	revision	by	date

CIVIL ENGINEERING  
202 REPUBLIC LN  
EULESS, TX 76040  
PH: (972) 523-5493  
TBPE: F-19293

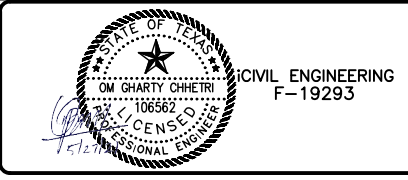

scale  
horiz N/A  
vert N/A  
date  
MAY 2021



STORM DRAIN PROFILES  
**NEPALI CULTURAL AND SPIRITUAL CENTER  
PHASE-I**  
1212 ROYAL PARKWAY, EULESS TEXAS 76040

PROJECT NO.  
JN 1120  
sheet  
12  
of  
23

# PIPE FLOW COMPUTATIONS

Line ID	LineLength (ft)	Incr.Area (ac)	TotalArea (ac)	RunoffCoeff. (C)	IncrC x A	TotalC x A	InletTime (min)	TimeConc (min)	RnfallInt (in/hr)	TotalRunoff (cfs)	TotalFlow (cfs)	CapacFull (cfs)	Veloc (ft/s)	PipeSize (in)	PipeSlope (%)	Inv ElevDn (ft)	Inv ElevUp (ft)	HGLDn (ft)	HGLUp (ft)	Grnd/RimDn (ft)	Grnd/RimUp (ft)
A-1	28	0	4.17	0	0	3.75	0	11.5	11.2	42.05	42.05	120.51	8.93	30	7.36	522	524.06	524.5	526.23	0	532.3
A-2	32	0	3.88	0	0	3.49	0	11.4	11.2	39.23	39.23	62.83	8.43	30	2	524.06	524.7	526.58	526.81	532.3	535.6
A-3	14.32	0	3.88	0	0	3.49	0	11.4	11.2	39.28	39.28	63.22	8.55	30	2.02	524.7	524.99	527.04	527.1	535.6	536.3
A-4	35	0	3.88	0	0	3.49	0	11.3	11.3	39.39	39.39	62.83	8.58	30	2	524.99	525.69	527.33	527.8	536.3	536.6
A-5	151.63	0	3.31	0	0	2.98	0	11	11.4	34.08	34.08	62.81	7.55	30	2	525.69	528.72	528.28	530.7	536.6	536.1
A-6	20.51	0	2.45	0	0	2.21	0	10.9	11.5	25.27	25.27	34.64	9.26	24	2	529.22	529.63	530.73	531.4	536.1	536.5
A-7	37	0	2.45	0	0	2.21	0	10.8	11.5	25.34	25.34	34.65	8.41	24	2	529.63	530.37	531.54	532.14	536.5	538.5
A-8	91.67	0	1.25	0	0	1.13	0	10.6	11.6	13.04	13.04	39.41	7.58	18	12	530.87	541.87	532.45	543.22	538.5	548.5
A-9	35	0	0.83	0	0	0.75	0	10.5	11.6	8.7	8.7	19.7	5.48	18	3	541.87	542.92	543.78	544.06	548.5	547.5
A-10	54.09	0	0.83	0	0	0.75	0	10.3	11.7	8.76	8.76	19.69	5.68	18	2.99	542.92	544.54	544.24	545.68	547.5	551
A-11	94	0	0.83	0	0	0.75	0	10	11.9	8.87	8.87	22.81	5.73	18	4.02	544.54	548.32	545.86	549.47	551	553.3
A-12	4	0.83	0.83	0.9	0.75	0.75	10	10	11.9	8.87	8.87	23.45	5.71	18	4.25	548.32	548.49	549.66	549.64	553.3	553.21
B-1	9.9	0	0.29	0	0	0.26	0	10.1	11.8	3.09	3.09	12.2	4.39	12	10	525.56	526.55	527.33	527.3	532.3	534.4
B-2	22	0	0.29	0	0	0.26	10	10	11.9	3.1	3.1	12.34	4.41	12	10.23	526.55	528.8	527.7	529.55	534.4	534.5
B-3	4.95	0.29	0.29	0.9	0.26	0.26	10	10	11.9	3.1	3.1	3.88	4.55	12	1.01	528.8	528.85	529.68	529.6	534.5	535.4
C-1	16.97	0	0.57	0	0	0.51	0	10.7	11.6	5.93	5.93	7.81	3.36	18	0.47	526.69	526.77	528.86	528.91	536.6	537.4
C-2	53	0	0.57	0	0	0.51	0	10.4	11.7	5.99	5.99	50.64	4.25	18	19.81	526.77	537.27	529.04	538.21	537.4	545.57
C-3	87	0.57	0.57	0.9	0.51	0.51	10	10	11.9	6.09	6.09	11.38	4.64	18	1	537.27	538.14	538.44	539.09	545.57	541
D-1	34	0	0.86	0	0	0.77	0	10.4	11.7	9.04	9.04	44.43	1.84	30	1	528.72	529.06	531.69	531.7	536.1	535.8
D-2	54.25	0	0.51	0	0	0.46	0	10.1	11.8	5.42	5.42	11.35	3.3	18	1	530.06	530.6	531.74	531.82	535.8	535.5
D-3	23	0.51	0.51	0.9	0.46	0.46	10	10	11.9	5.45	5.45	11.38	4.08	18	1	530.6	530.83	531.96	531.73	535.5	534.92
E-1	34.83	0.35	0.35	0.9	0.32	0.32	10	10	11.9	3.74	3.74	3.87	4.76	12	1	530.56	530.91	531.74	532.07	535.8	534.83
F-1	16.44	0	1.2	0	0	1.08	0	10.1	11.8	12.76	12.76	19.64	7.44	18	2.98	530.87	531.36	532.48	532.7	538.5	540
F-2	56.5	1.2	1.2	0.9	1.08	1.08	10	10	11.9	12.83	12.83	19.73	7.53	18	3.01	531.36	533.06	532.79	534.4	540	538
G-1	56	0	0.42	0	0	0.38	0	10.4	11.7	4.42	4.42	3.86	5.63	12	1	542.37	542.93	543.67	544.4	548.5	547
G-2	6.2	0	0.42	0	0	0.38	0	10.3	11.7	4.43	4.43	3.8	5.64	12	0.97	542.93	542.99	544.8	544.88	547	547
G-3	95	0	0.42	0	0	0.38	0	10.1	11.8	4.48	4.48	10.9	5.9	12	7.99	542.99	550.58	545.26	551.46	547	554
G-4	23.88	0.42	0.42	0.9	0.38	0.38	10	10	11.9	4.49	4.49	10.91	5.96	12	8	550.58	552.49	551.53	553.38	554	555

# INLET COMPUTATIONS

Inlet ID	Area (ac)	InletTime (min)	Int. (in/hr)	RunoffCoeff. (C)	Q=CIA (cfs)	QCaptured (cfs)	QBypassed (cfs)	JunctType	CurbHeight (in)	CurbLength (ft)	GrateArea (sqft)	GrateLength (ft)	GrateWidth (ft)	GutterSlope (ft/ft)	GutterWidth (ft)	CrossSlope, Sw (ft/ft)	CrossSlope, Sx (ft/ft)	LocalDepr. (in)	InletDepth (ft)	BypassDepth (ft)	BypassSpread (ft)	GutterDepth (ft)	GutterSpread (ft)	BypassLine No.
I-1	0.83	10	11.88	0.9	8.87	8.87	0	Curb	6	10	....	....	....	Sag	2	0.04	0.02	0	0.47	n/a	n/a	0.47	21.57	Sag
I-2	0.29	10	11.88	0.9	3.1	3.1	0	Curb	6	10	....	....	....	Sag	2	0.04	0.02	0	0.25	n/a	n/a	0.25	10.7	Sag
I-3	0.57	10	11.88	0.9	6.09	6.09	0	Dp-Grate	....	....	10	20	0.5	Sag	5	0.02	0.02	....	0.13	n/a	n/a	0.13	18.47	Sag
I-4	0.51	10	11.88	0.9	5.45	5.45	0	Curb	6	10	....	....	....	Sag	2	0.04	0.02	0	0.35	n/a	n/a	0.35	15.59	Sag
I-5	0.35	10	11.88	0.9	3.74	3.74	0	Curb	6	10	....	....	....	Sag	2	0.04	0.02	0	0.28	n/a	n/a	0.28	12.13	Sag
I-6	1.2	10	11.88	0.9	12.83	12.83	0	Dp-Grate	....	....	10	20	0.5	Sag	5	0.02	0.02	....	0.22	n/a	n/a	0.22	27.14	Sag
I-7	0.42	10	11.88	0.9	4.49	4.49	0	Curb	6	10	....	....	....	Sag	2	0.04	0.02	0	0.31	n/a	n/a	0.31	13.7	Sag

no.	revision	by	date

iCIVIL ENGINEERING  
202 REPUBLIC LN  
EULESS, TX 76040  
PH: (972) 523-5493  
  
TBPE: F-19293

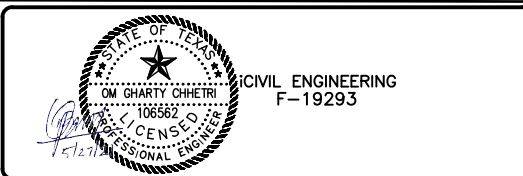

scale  
horiz  
N/A  
vert  
N/A  
date  
MAY 2021



DRAINAGE CALCULATIONS  
**NEPALI CULTURAL AND SPIRITUAL CENTER  
PHASE-I**  
1212 ROYAL PARKWAY, EULESS TEXAS 76040

PROJECT NO.  
JN 1120  
sheet  
13  
of  
23

# HIGHWAY DESIGNATION: S.H.-10

## POND SUMMARY

AREA (ACRE)	PEAK RUNOFF (INFLOW) (CFS)				PEAK RUNOFF (OUTFLOW) (CFS)				REMARKS
	5 YRS	10 YRS	25 YRS	100 YRS	5 YRS	10 YRS	25 YRS	100 YRS	
4.46	26.47	25.00	37.33	47.74	15.98	18.09	19.70	22.32	AREA A-G DRAINS TO POND, ALLOWABLE PEAK RELEASE RATE (Q5)=26.47 < 22.32 (ACTUAL)

TOP OF POND-527.00  
 BOTTOM OF POND-522.00  
 NOTE- CURRENT TXDOT STORM DRAIN SYSTEM ARE DESIGNED TO CONVEY DEVELOPED Q5 RUNOFF FROM PROJECT SITE. REFER TXDOT PROJECT NO. CCSJ-0094-02-074.

# W EULESS BLVD(S.H.-10)

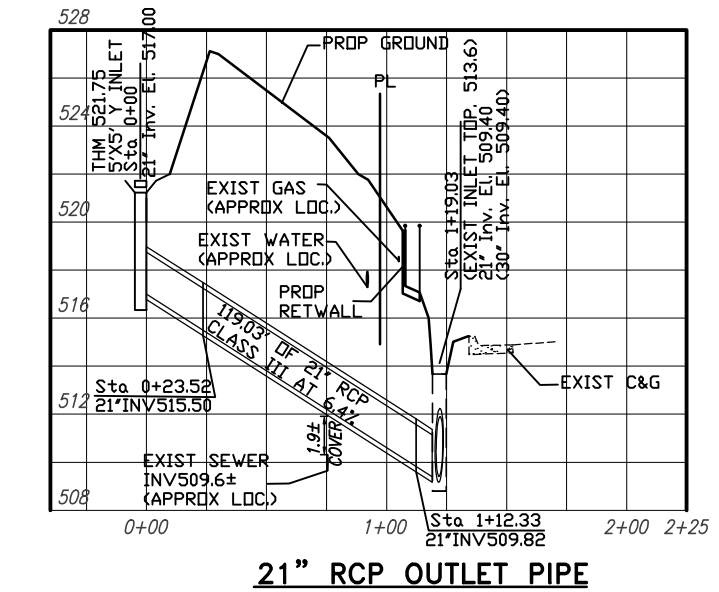
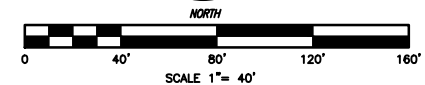
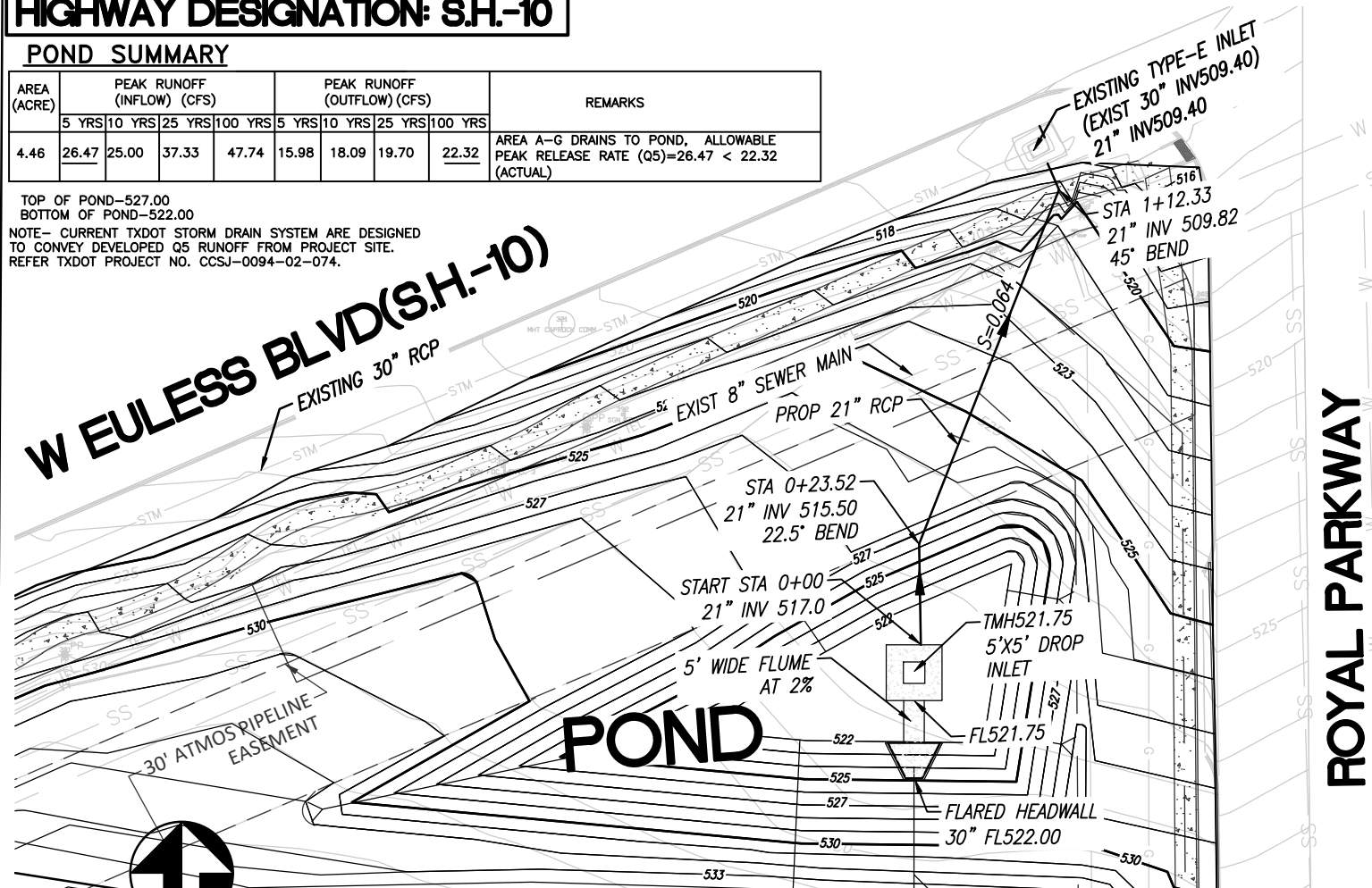

## Pond Report

Hydraulflow Hydrographs Extension for Autodesk® Civil 3D® by Autodesk, Inc. v2020 Thursday, 05 / 6 / 2021

**Pond No. 1 - NCSC POND**  
**Pond Data**  
 Pond storage is based on user-defined values.

Stage (ft)	Elevation (ft)	Contour area (sqft)	Incr. Storage (cuft)	Total storage (cuft)
0.00	522.00	n/a	0	0
1.00	523.00	n/a	953	953
2.00	524.00	n/a	2,259	3,212
3.00	525.00	n/a	3,016	6,228
4.00	526.00	n/a	3,876	10,104
5.00	527.00	n/a	4,836	14,940

Culvert / Orifice Structures				Weir Structures			
	[A]	[B]	[C] [Pr/Rsr]		[A]	[B]	[C] [D]
Rise (in)	= 21.00	0.00	0.00	Crest Len (ft)	= 0.00	0.00	0.00
Span (in)	= 21.00	0.00	0.00	Crest El. (ft)	= 0.00	0.00	0.00
No. Barrels	= 1	0	0	Weir Coeff.	= 3.33	3.33	3.33
Invert El. (ft)	= 522.00	0.00	0.00	Weir Type	=		
Length (ft)	= 119.00	0.00	0.00	Multi-Stage	= No	No	No
Slope (%)	= 6.40	0.00	n/a	Exfil. (in/hr)	= 0.000 (by Wet area)		
N-Value	= .013	.013	n/a	TW Elev. (ft)	= 0.00		
Orifice Coeff.	= 0.60	0.60	0.60				
Multi-Stage	= n/a	No	No				

Stage ft	Storage cuft	Elevation ft	Civ A cfs	Civ B cfs	Civ C cfs	Pr/Rsr cfs	Wr A cfs	Wr B cfs	Wr C cfs	Wr D cfs	Exfil cfs	User cfs	Total cfs
0.00	0	522.00	0.00	---	---	---	---	---	---	---	---	---	0.000
1.00	953	523.00	4.84 ic	---	---	---	---	---	---	---	---	---	4.843
2.00	3,212	524.00	12.28 ic	---	---	---	---	---	---	---	---	---	12.288
3.00	6,228	525.00	18.88 ic	---	---	---	---	---	---	---	---	---	18.888
4.00	10,104	526.00	20.47 ic	---	---	---	---	---	---	---	---	---	20.477
5.00	14,940	527.00	23.52 ic	---	---	---	---	---	---	---	---	---	23.527

## Hydrograph Report

Hydraulflow Hydrographs Extension for Autodesk® Civil 3D® by Autodesk, Inc. v2020 Monday, 11 / 23 / 2020

**Hyd. No. 3**  
 INFLOW-OUTFLOW  
 Hydrograph type = Reservoir  
 Storm frequency = 5 yrs  
 Time interval = 1 min  
 Inflow hyd. No. = 2 - POST DEV HYDROGRAPH  
 Reservoir name = NCSC POND  
 Peak discharge = 15.98 cfs  
 Time to peak = 14 min  
 Hyd. volume = 15,860 cuft  
 Max. Elevation = 524.78 ft  
 Max. Storage = 5,567 cuft

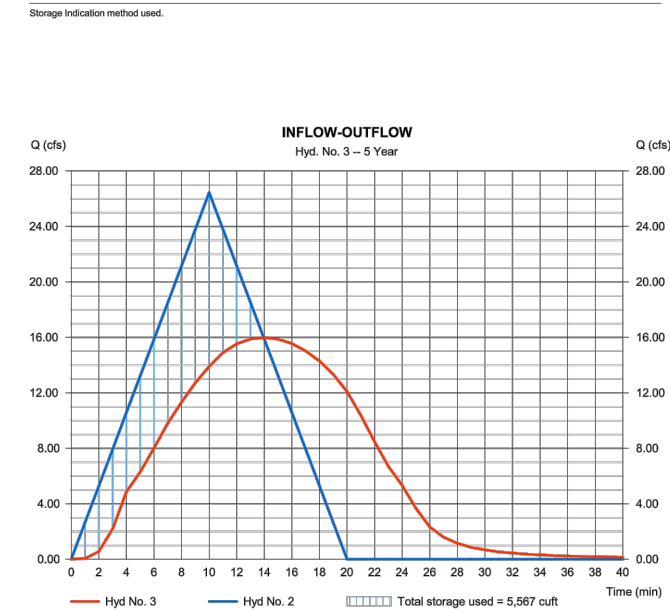

## Hydrograph Report

Hydraulflow Hydrographs Extension for Autodesk® Civil 3D® by Autodesk, Inc. v2020 Tuesday, 12 / 15 / 2020

**Hyd. No. 3**  
 INFLOW-OUTFLOW  
 Hydrograph type = Reservoir  
 Storm frequency = 10 yrs  
 Time interval = 1 min  
 Inflow hyd. No. = 2 - POST DEV HYDROGRAPH  
 Reservoir name = NCSC POND  
 Peak discharge = 18.09 cfs  
 Time to peak = 14 min  
 Hyd. volume = 19,487 cuft  
 Max. Elevation = 525.32 ft  
 Max. Storage = 7,449 cuft

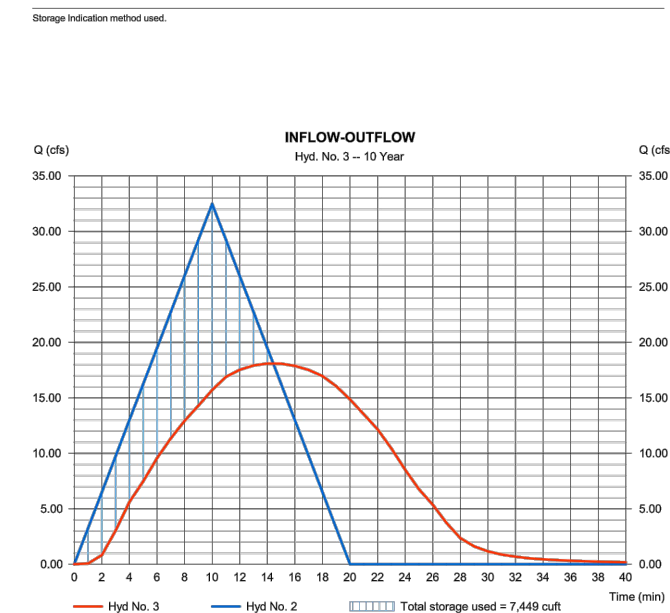

## Hydrograph Report

Hydraulflow Hydrographs Extension for Autodesk® Civil 3D® by Autodesk, Inc. v2020 Tuesday, 12 / 15 / 2020

**Hyd. No. 3**  
 INFLOW-OUTFLOW  
 Hydrograph type = Reservoir  
 Storm frequency = 25 yrs  
 Time interval = 1 min  
 Inflow hyd. No. = 2 - POST DEV HYDROGRAPH  
 Reservoir name = NCSC POND  
 Peak discharge = 19.70 cfs  
 Time to peak = 15 min  
 Hyd. volume = 22,546 cuft  
 Max. Elevation = 525.77 ft  
 Max. Storage = 9,209 cuft

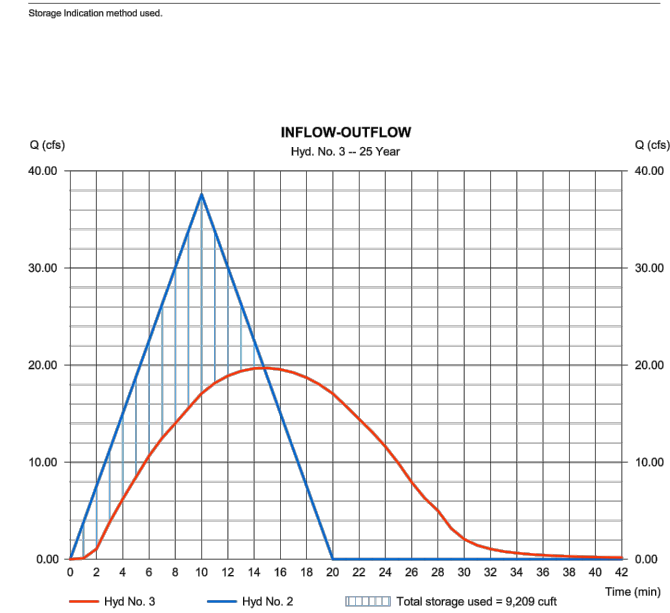

## Hydrograph Report

Hydraulflow Hydrographs Extension for Autodesk® Civil 3D® by Autodesk, Inc. v2020 Monday, 11 / 23 / 2020

**Hyd. No. 3**  
 INFLOW-OUTFLOW  
 Hydrograph type = Reservoir  
 Storm frequency = 100 yrs  
 Time interval = 1 min  
 Inflow hyd. No. = 2 - POST DEV HYDROGRAPH  
 Reservoir name = NCSC POND  
 Peak discharge = 22.32 cfs  
 Time to peak = 15 min  
 Hyd. volume = 28,599 cuft  
 Max. Elevation = 526.59 ft  
 Max. Storage = 12,961 cuft

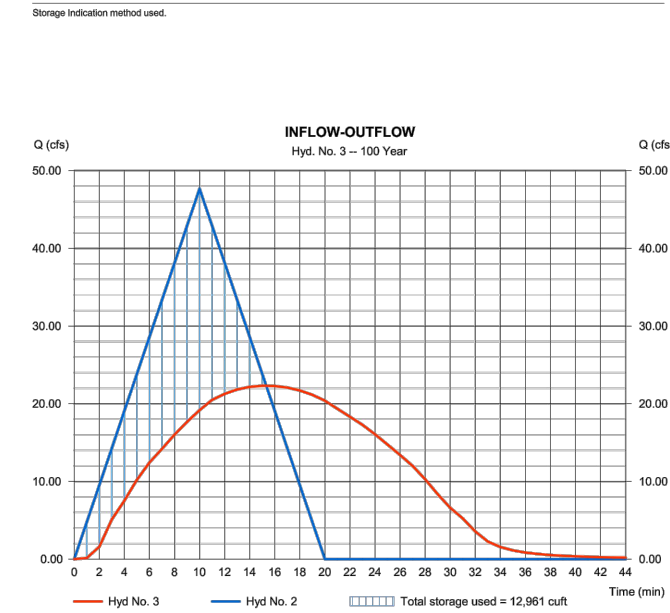

no.	revision	by	date

iCIVIL ENGINEERING  
 202 REPUBLIC LN  
 EULESS, TX 76040  
 PH: (972) 523-5493  
 TBPE: F-19293

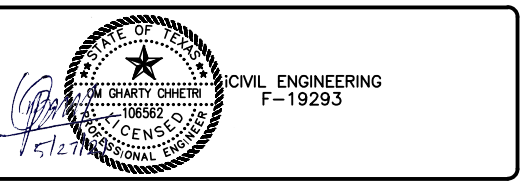

scale  
 horiz N/A  
 vert N/A  
 date  
 MAY 2021



POND CALCULATIONS  
**NEPALI CULTURAL AND SPIRITUAL CENTER**  
 PHASE-I  
 1212 ROYAL PARKWAY, EULESS TEXAS 76040

PROJECT NO. JN 1120  
 sheet 14 of 23

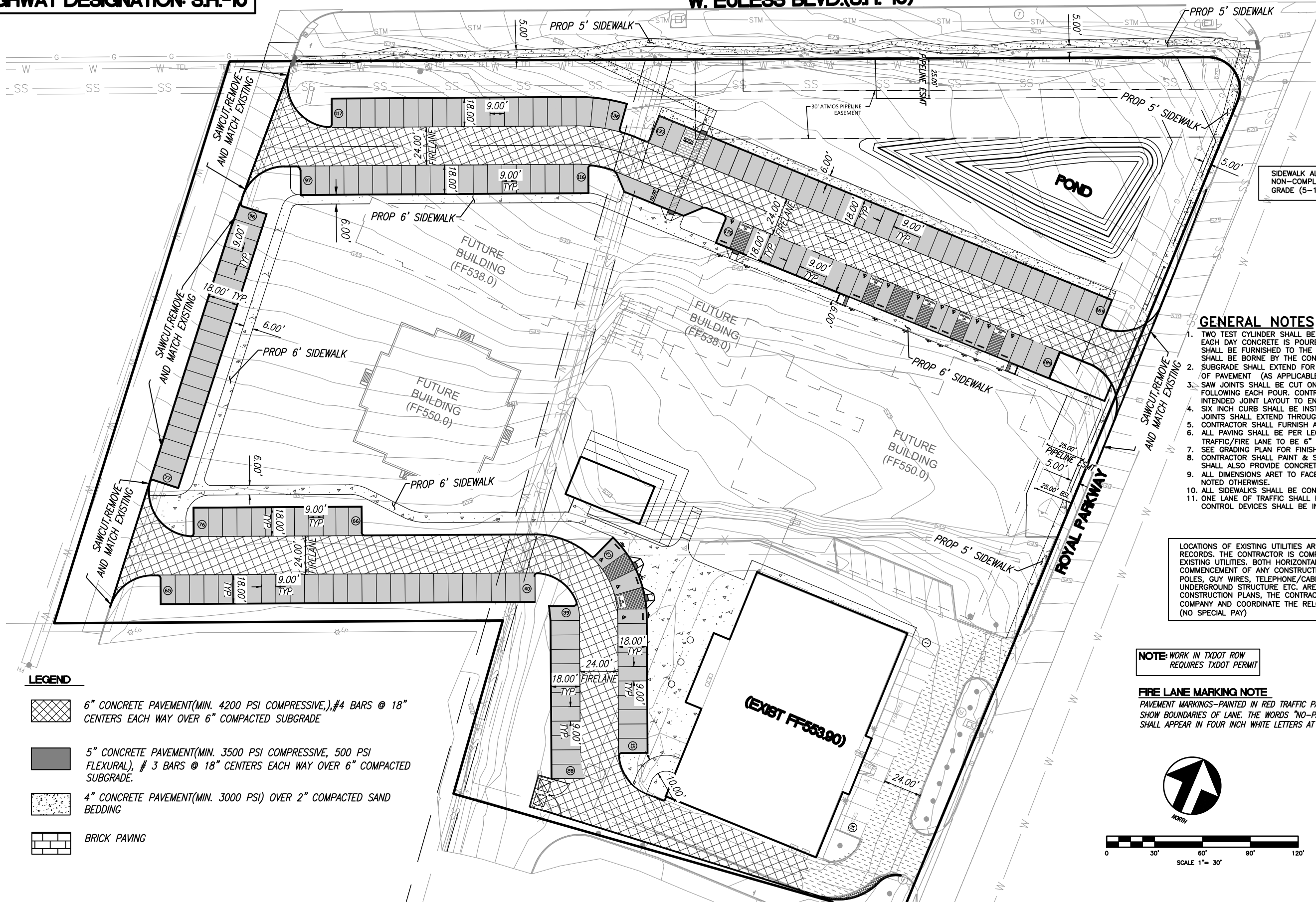

SIDEWALK ALONG ROYAL PARKWAY IS ADA NON-COMPLIANT. THE SIDEWALK FOLLOW THE STREET GRADE (5-12%)

**GENERAL NOTES**

1. TWO TEST CYLINDER SHALL BE TAKEN BY AN APPROVED TESTING LABORATORY EACH DAY CONCRETE IS POURED. SEVEN DAY AND 28 DAY TEST RESULTS SHALL BE FURNISHED TO THE OWNER AND ENGINEER. ALL COSTS FOR TESTING SHALL BE BORNE BY THE CONTRACTOR.
2. SUBGRADE SHALL EXTEND FOR A MIN. OF 12" BEYOND LIMITS OF CURB/EDGE OF PAVEMENT (AS APPLICABLE)
3. SAW JOINTS SHALL BE CUT ON MAXIMUM OF 15' CENTERS WITHIN 12 HOURS FOLLOWING EACH POUR. CONTRACTOR SHALL SUBMIT SHOP DRAWING OF INTENDED JOINT LAYOUT TO ENGINEER FOR APPROVAL PRIOR TO CONSTRUCTION.
4. SIX INCH CURB SHALL BE INSTALLED INTEGRAL WITH CONCRETE PAVEMENT. SAW JOINTS SHALL EXTEND THROUGH THE CURB.
5. CONTRACTOR SHALL FURNISH ALL CONSTRUCTION STAKING.
6. ALL PAVING SHALL BE PER LEGEND OR PER GEOTECHNICAL REPORT, TRAFFIC/FIRE LANE TO BE 6" THICK.
7. SEE GRADING PLAN FOR FINISHED PAVEMENT ELEVATIONS.
8. CONTRACTOR SHALL PAINT & STRIPE ALL PARKING AS SHOWN. CONTRACTOR SHALL ALSO PROVIDE CONCRETE RAMPS, SIGNS AND CURB STOPS AS SHOWN.
9. ALL DIMENSIONS ARE TO FACE OF CURB/ OR EDGE OF PAVEMENT UNLESS NOTED OTHERWISE.
10. ALL SIDEWALKS SHALL BE CONSTRUCTED PER CITY STANDARDS.
11. ONE LANE OF TRAFFIC SHALL BE MAINTAINED AT ALL TIMES. ALL TRAFFIC CONTROL DEVICES SHALL BE IN ACCORDANCE WITH TMUTCD LATEST EDITIONS.

LOCATIONS OF EXISTING UTILITIES ARE APPROXIMATE AND ARE BASED ON PUBLIC RECORDS. THE CONTRACTOR IS COMPLETELY RESPONSIBLE FOR LOCATING ALL EXISTING UTILITIES, BOTH HORIZONTALLY AND VERTICALLY BEFORE THE COMMENCEMENT OF ANY CONSTRUCTION. IF ANY EXISTING UTILITY POLES, POWER POLES, GUY WIRES, TELEPHONE/CABLE UTILITIES, GAS UTILITIES OR ANY UNDERGROUND STRUCTURE ETC. ARE FOUND TO BE IN CONFLICT WITH THESE CONSTRUCTION PLANS, THE CONTRACTOR SHALL CONTACT THE APPROPRIATE UTILITY COMPANY AND COORDINATE THE RELOCATION OF ANY AND/OR ALL SUCH UTILITIES (NO SPECIAL PAY)

**NOTE: WORK IN TXDOT ROW REQUIRES TXDOT PERMIT**

**FIRE LANE MARKING NOTE**  
PAVEMENT MARKINGS-PAINTED IN RED TRAFFIC PAINT 6" IN WIDTH TO SHOW BOUNDARIES OF LANE. THE WORDS "NO-PARKING-FIRE LANE" SHALL APPEAR IN FOUR INCH WHITE LETTERS AT 25-FOOT INTERVALS.

**LEGEND**

- 6" CONCRETE PAVEMENT(MIN. 4200 PSI COMPRESSIVE.),#4 BARS @ 18" CENTERS EACH WAY OVER 6" COMPACTED SUBGRADE
- 5" CONCRETE PAVEMENT(MIN. 3500 PSI COMPRESSIVE, 500 PSI FLEXURAL), # 3 BARS @ 18" CENTERS EACH WAY OVER 6" COMPACTED SUBGRADE.
- 4" CONCRETE PAVEMENT(MIN. 3000 PSI) OVER 2" COMPACTED SAND BEDDING
- BRICK PAVING

no.	revision	by	date

CIVIL ENGINEERING  
202 REPUBLIC LN  
EULESS, TX 76040  
PH: (972) 523-5493  
  
TBPE: F-19293

CIVIL ENGINEERING  
F-19293

scale  
horiz  
N/A  
vert  
N/A  
date  
MAY 2021

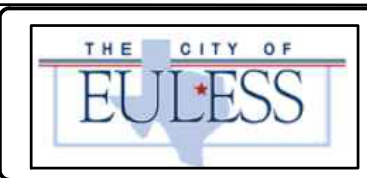

PAVING PLAN

**NEPALI CULTURAL AND SPIRITUAL CENTER  
PHASE-I**  
1212 ROYAL PARKWAY,EULESS TEXAS 76040

PROJECT NO.  
JN 1120  
sheet  
15  
of  
23

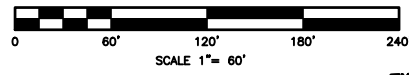
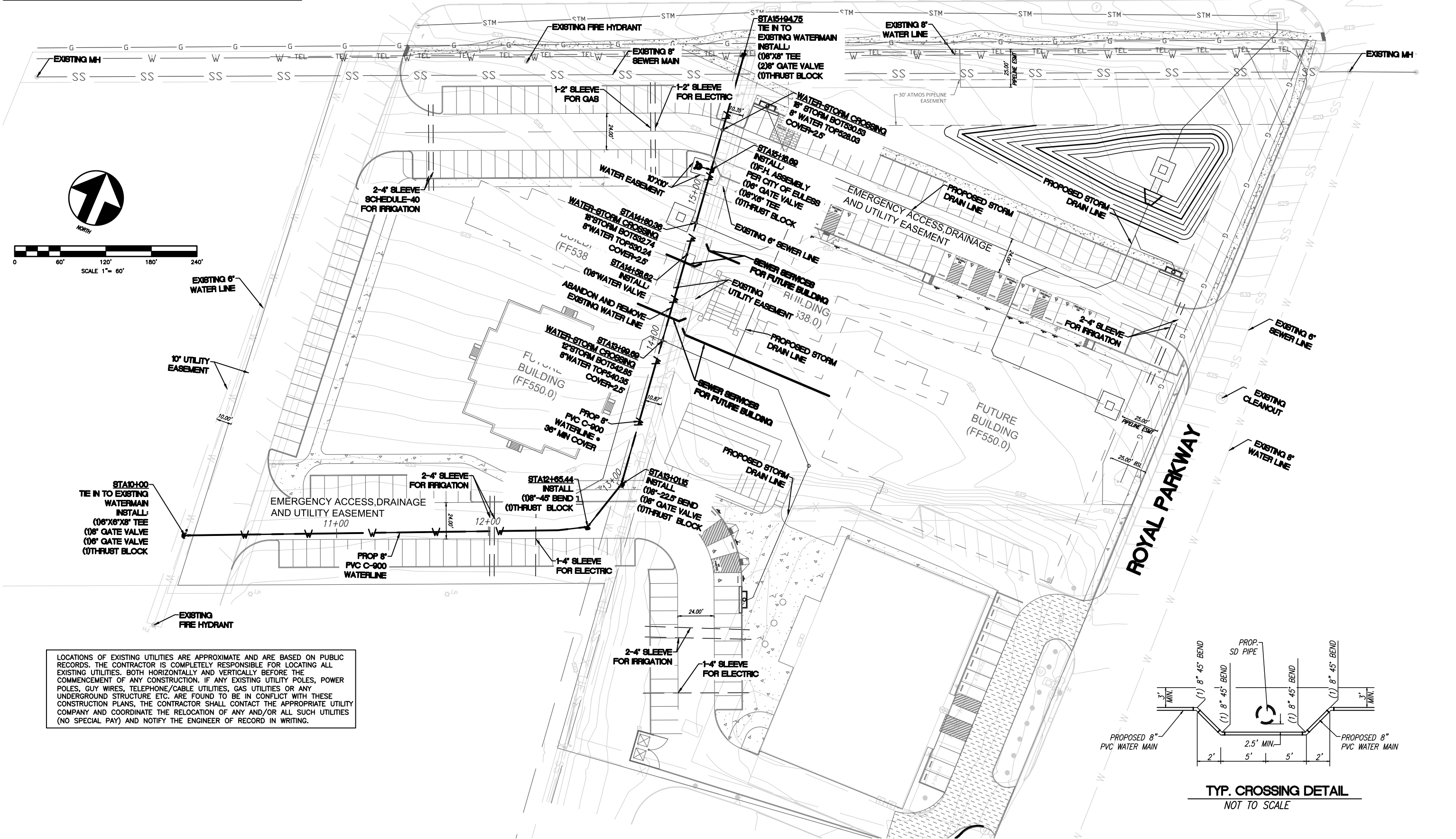

LOCATIONS OF EXISTING UTILITIES ARE APPROXIMATE AND ARE BASED ON PUBLIC RECORDS. THE CONTRACTOR IS COMPLETELY RESPONSIBLE FOR LOCATING ALL EXISTING UTILITIES, BOTH HORIZONTALLY AND VERTICALLY BEFORE THE COMMENCEMENT OF ANY CONSTRUCTION. IF ANY EXISTING UTILITY POLES, POWER POLES, GUY WIRES, TELEPHONE/CABLE UTILITIES, GAS UTILITIES OR ANY UNDERGROUND STRUCTURE ETC. ARE FOUND TO BE IN CONFLICT WITH THESE CONSTRUCTION PLANS, THE CONTRACTOR SHALL CONTACT THE APPROPRIATE UTILITY COMPANY AND COORDINATE THE RELOCATION OF ANY AND/OR ALL SUCH UTILITIES (NO SPECIAL PAY) AND NOTIFY THE ENGINEER OF RECORD IN WRITING.

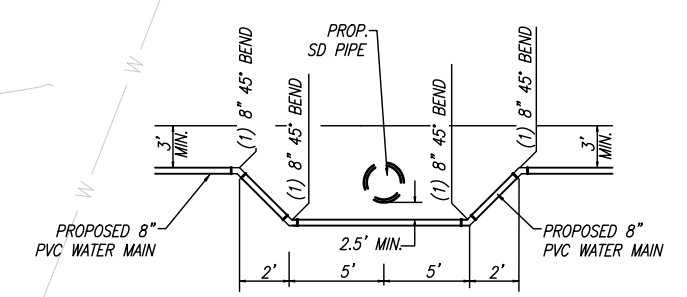

**TYP. CROSSING DETAIL**  
NOT TO SCALE

no.	revision	by	date

iCIVIL ENGINEERING  
202 REPUBLIC LN  
EULESS, TX 76040  
PH: (972) 523-5493  
  
TBPE: F-19293

iCIVIL ENGINEERING  
F-19293

scale  
horiz  
N/A  
vert  
N/A  
date  
MAY 2021



WATER AND SEWER PLAN  
**NEPALI CULTURAL AND SPIRITUAL CENTER**  
**PHASE-I**  
1212 ROYAL PARKWAY, EULESS TEXAS 76040

PROJECT NO.  
JN 1120  
sheet  
16  
of  
23



**HIGHWAY DESIGNATION: S.H.-10**

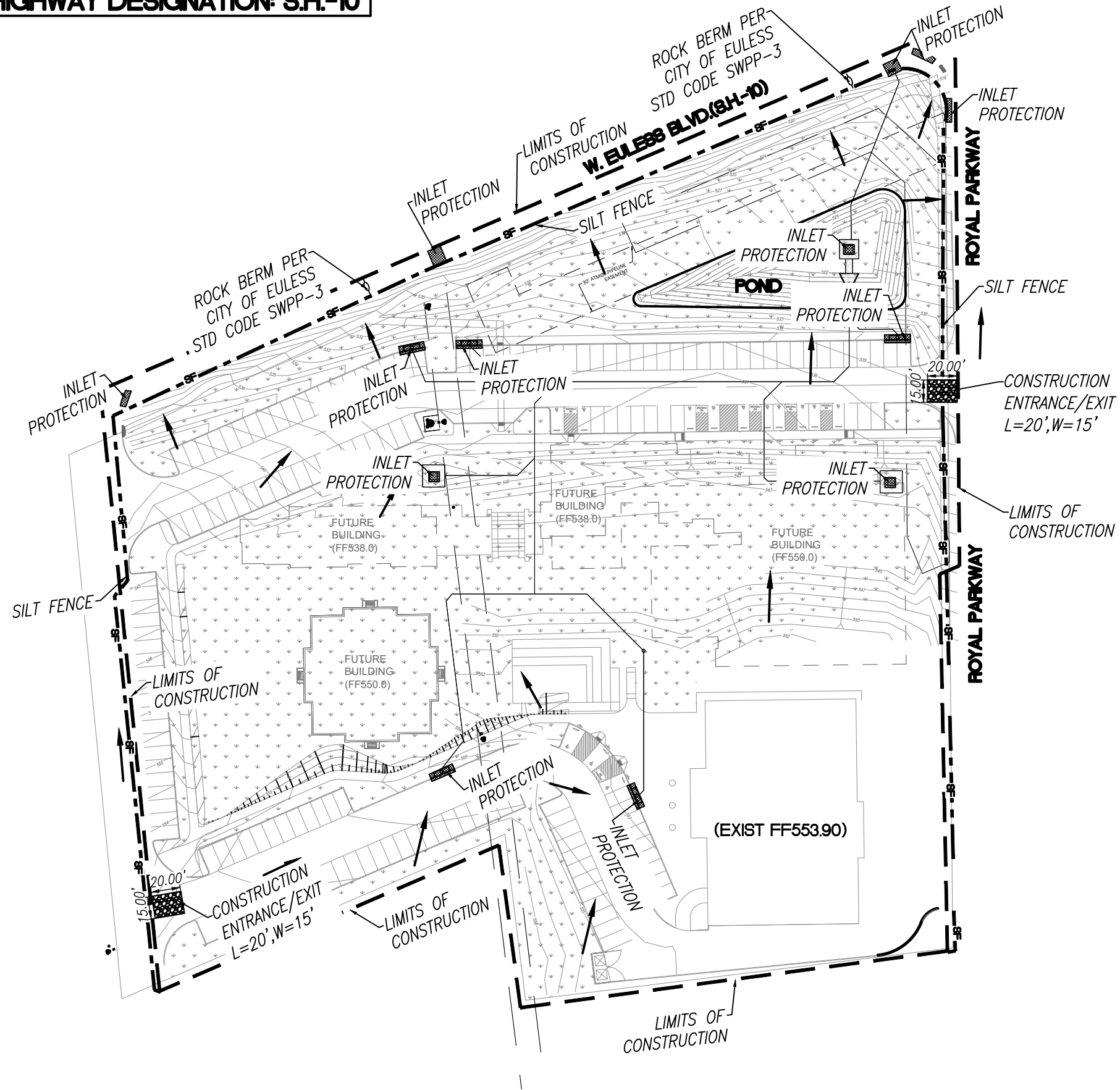
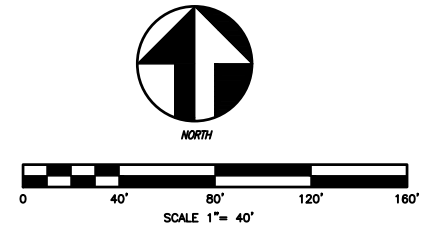

**LEGEND**

- SILT FENCE OR APPROVED EQUAL/LIMIT OF CONSTRUCTION
- DRAINAGE FLOW DIRECTION
- CONSTRUCTION ENTRANCE/EXIT
- SODDING

**PHASE DESCRIPTION**

- 1 INSTALL INITIAL BMPs
- 2 GRADING & POND
- 3 UNDERGROUND UTILITY INSTALLATION
- 4 PAVING OPERATIONS
- 5 ESTABLISH PERMANENT GROUND COVER
- 6 REMOVE TEMPORARY BMPs

**EROSION AND SEDIMENT CONTROL**

**1. SOIL STABILIZATION PRACTISES (T-TEMPORARY P-PERMANENT)**

- P BUFFER ZONE
- P PLANTING
- P SODDING
- P RIPRAP AT OUTLET

**2. STRUCTURAL PRACTISES**

- I SILT FENCE
- I ROCK FILTER DAMS
- P CURB & GUTTER
- P INLETS AND PIPES
- P PAVED FLUMES
- I STORM INLET SEDIMENT TRAP
- P PIPE SLOPE DRAINS

no.	revision	by	date

iCIVIL ENGINEERING  
202 REPUBLIC LN  
EULESS, TX 76040  
PH: (972) 523-5493  
  
TBPE: F-19293

OM CHARTY CHHETRI  
106562  
LICENSED PROFESSIONAL ENGINEER  
CIVIL ENGINEERING  
F-19293

scale  
horiz  
N/A  
vert  
N/A  
date  
MAY 2021



EROSION CONTROL PLAN  
**NEPALI CULTURAL AND SPIRITUAL CENTER**  
**PHASE-I**  
1212 ROYAL PARKWAY, EULESS TEXAS 76040

PROJECT NO.  
JN 1120  
sheet  
17  
of  
23

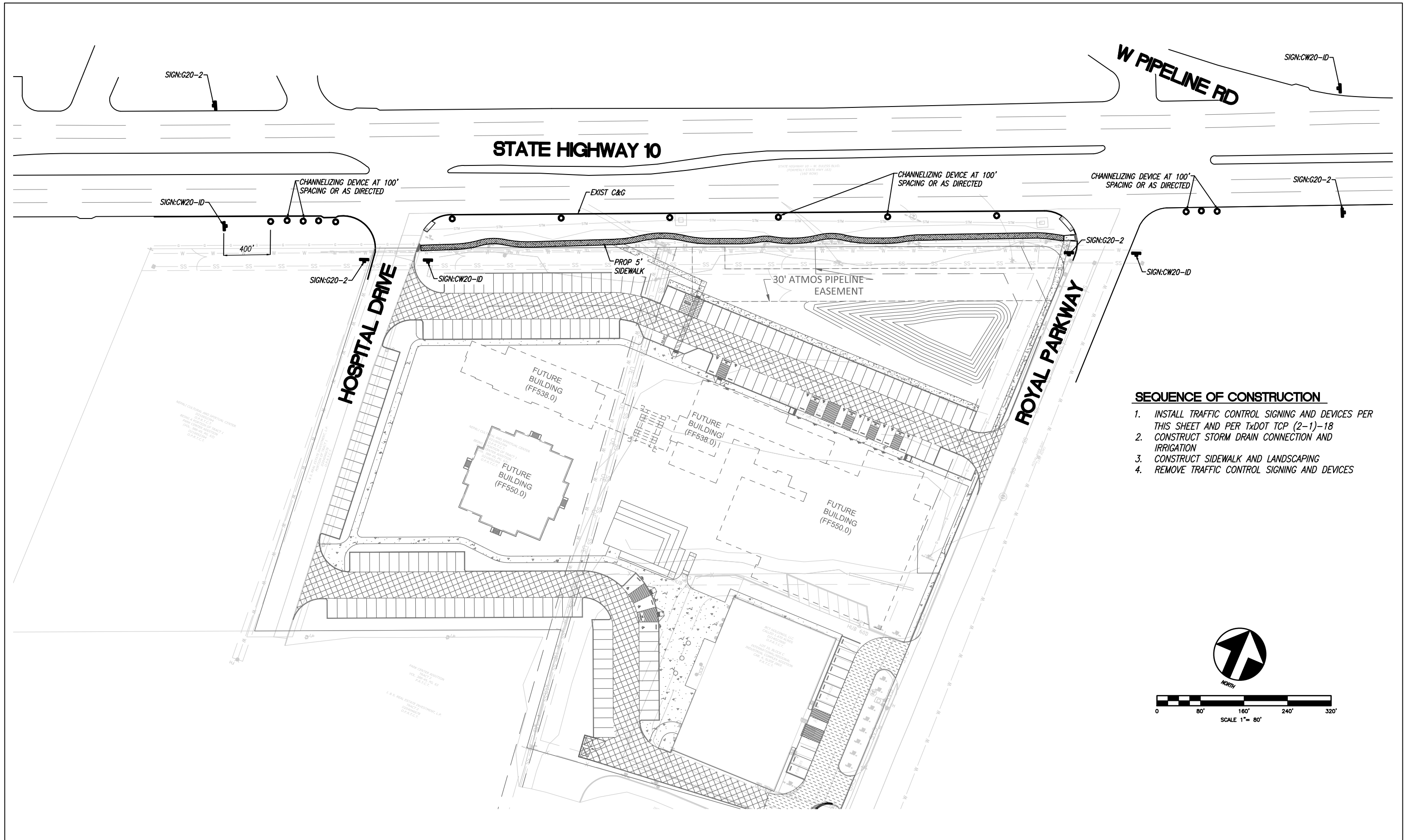

**SEQUENCE OF CONSTRUCTION**

1. INSTALL TRAFFIC CONTROL SIGNING AND DEVICES PER THIS SHEET AND PER TxDOT TCP (2-1)-18
2. CONSTRUCT STORM DRAIN CONNECTION AND IRRIGATION
3. CONSTRUCT SIDEWALK AND LANDSCAPING
4. REMOVE TRAFFIC CONTROL SIGNING AND DEVICES

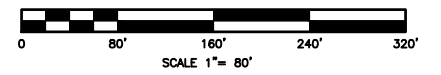

no.	revision	by	date

ICIVIL ENGINEERING  
 202 REPUBLIC LN  
 EULESS, TX 76040  
 PH: (972) 523-5493  
 TBPE: F-19293

ICIVIL ENGINEERING  
 F-19293

scale  
 horiz  
 N/A  
 vert  
 N/A  
 date  
 MAY 2021

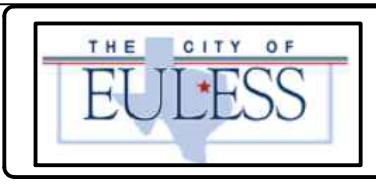

**PRELIMINARY PLAN**  
 For Review Only  
 This document is released for the purpose of interim review and markup under the authority of OM GHARTY CHHETRI, P.E. Licence No: 106562 on 5/28/21. This document is not to be used for construction, bidding or permit purposes.

**TRAFFIC CONTROL PLAN**  
 NEPALI CULTURAL AND SPIRITUAL CENTER  
 PHASE-I  
 1212 ROYAL PARKWAY, EULESS TEXAS 76040

PROJECT NO.  
 JN 1120  
 sheet  
 18  
 of  
 23

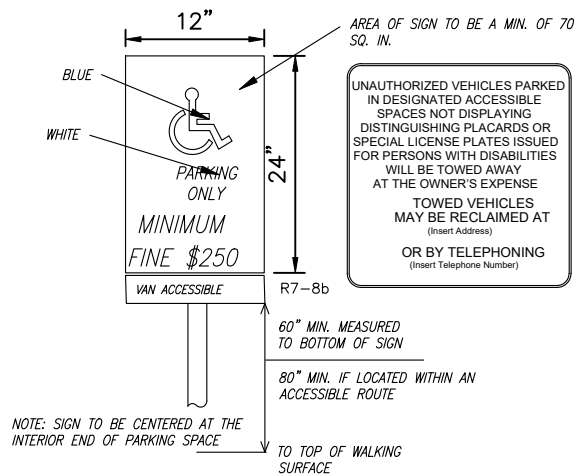

**ADA PARKING SIGN DETAIL**  
NOT TO SCALE

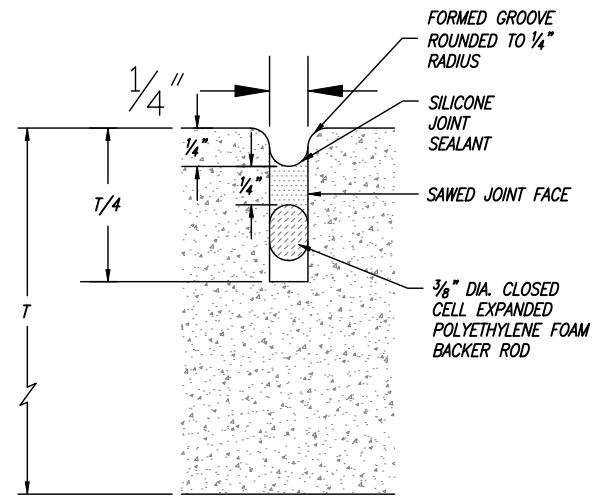

**SAWED JOINT DETAIL**  
NOT TO SCALE

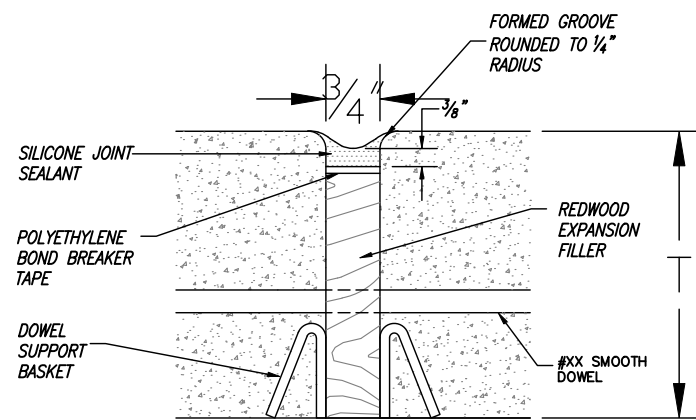

**REDWOOD EXPANSION JOINT DETAIL**  
NOT TO SCALE

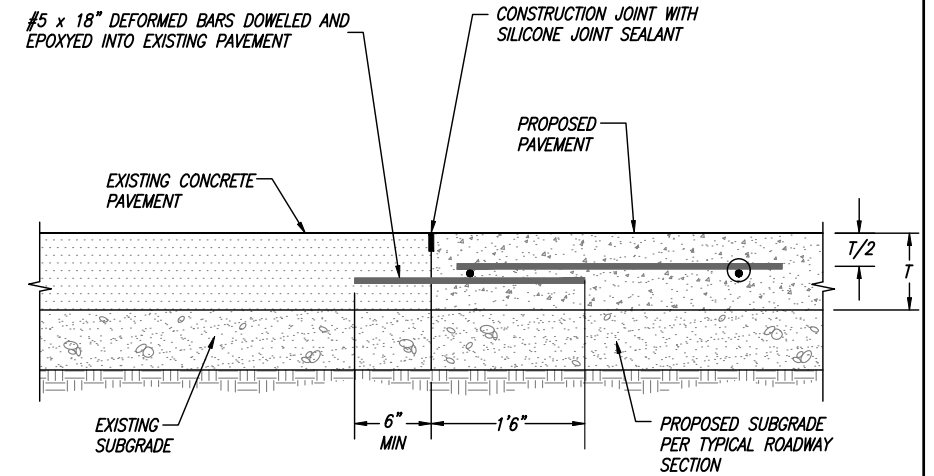

**CONSTRUCTION JOINT (BETWEEN EXISTING AND PROPOSED PAVEMENT)**  
NOT TO SCALE

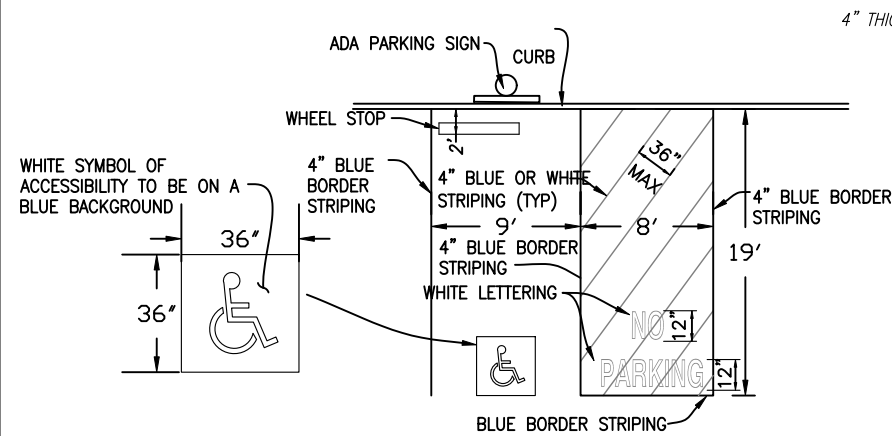

**ADA STRIPING DETAIL**  
NOT TO SCALE

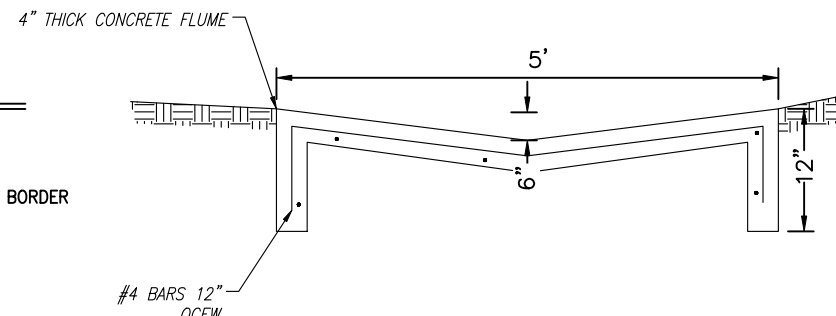

**PROPOSED CONCRETE FLUME**  
NOT TO SCALE

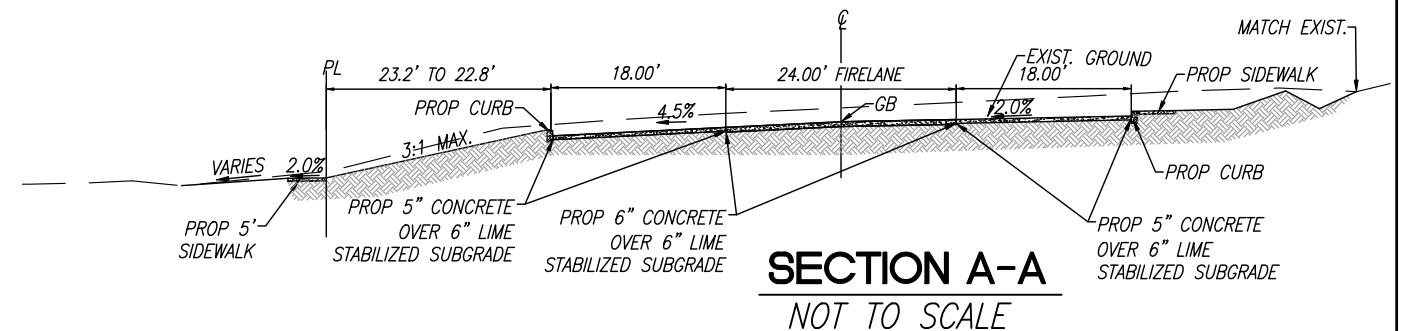

**SECTION A-A**  
NOT TO SCALE

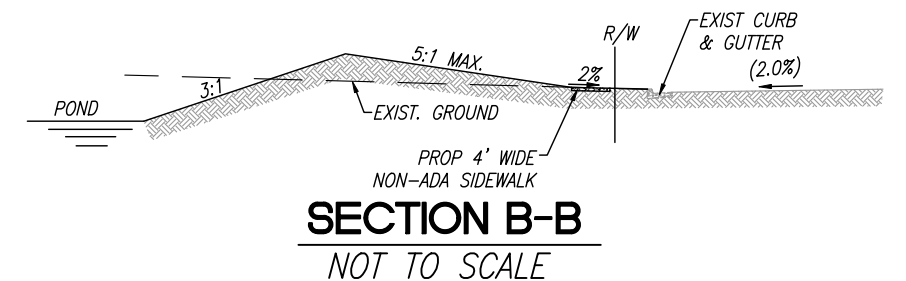

**SECTION B-B**  
NOT TO SCALE

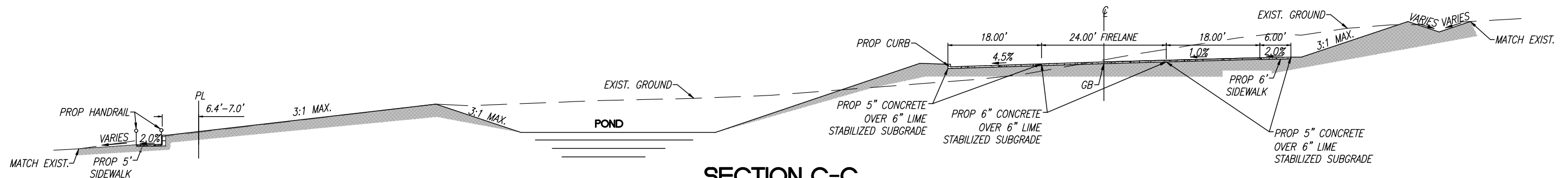

**SECTION C-C**  
NOT TO SCALE

no.	revision	by	date

iCIVIL ENGINEERING  
202 REPUBLIC LN  
EULESS, TX 76040  
PH: (972) 523-5493  
TBPE: F-19293

iCIVIL ENGINEERING  
F-19293

scale  
horiz  
N/A  
vert  
N/A  
date  
MAY 2021



SITE DETAILS & SECTIONS  
**NEPALI CULTURAL AND SPIRITUAL CENTER  
PHASE-I**  
1212 ROYAL PARKWAY, EULESS TEXAS 76040

PROJECT NO.  
JN 1120  
sheet  
19  
of  
23

PLANT LEGEND					
SYMBOL	AMOUNT	COMMON NAME	SCIENTIFIC NAME	SIZE	SPACING
	15	LIVE OAK	QUERCUS VIRGINIANA	4" CALIPER 100 GAL	AS SHOWN
	14	SHUMARD RED OAK	QUERCUS SHUMARDI	4" CALIPER 100 GAL	AS SHOWN
	11	MAGNOLIA 'D.D. BLANCHARD'	MAGNOLIA GRANDIFLORA 'DD BLANCHARD'	100 GALLON	AS SHOWN
	12	LITTLE GEM MAGNOLIA	MAGNOLIA GRANDIFLORA 'LITTLE GEM'	100 GALLON	AS SHOWN
	10	EASTERN REDBUD	CERCIS CANADENSIS	45 GALLON	AS SHOWN
	195	DWARF YAUPOH HOLLY	ILEX VOMITORIA 'NANA'	7 GALLON	AS SHOWN
	300	DWARF BURFORD HOLLY	ILEX CORNUTA 'DWARF BURFORD'	7 GALLON	AS SHOWN
	47	SUNSHINE LIGUSTRUM	LIGUSTRUM SINENSE 'SUNSHINE'	7 GALLON	AS SHOWN
	207	ABELIA 'KALEIDOSCOPE'	ABELIA X GRANDIFLORA 'KALEIDOSCOPE'	3 GALLON	AS SHOWN
	22	SALVIA GREGGI - PINK	SALVIA GREGGI	3 GALLON	24" O.C.
	210	PINK MUHLY GRASS	MUHLENBERGIA CAPILLARIS	1 GALLON	36" O.C. OR AS SHOWN
	141	LIRIOPE 'BIG BLUE'	LIRIOPE MUSCARI	1 GALLON	12" O.C.
	354	ANNUAL COLOR	4" POTS COLOR SCHEME - RED/PINK/WHITE	SQUARE FEET	100% COVERAGE
	700	ASIAN JASMINE GROUNDCOVER	4" POTS BROWN METAL EDGING AROUND	SQUARE FEET	100% COVERAGE
	143,555	BERMUDA SOD TIF 419		SQUARE FEET	100% COVERAGE
	1,910	4" BROWN METAL EDGING		LINEAR FEET	

GENERAL LANDSCAPE NOTES

LANDSCAPE STANDARDS

1. PLANTINGS AND LANDSCAPE ELEMENTS SHALL COMPLY WITH THE CITY'S ENGINEERING DESIGN STANDARDS & PUBLIC R.O.W. VISIBILITY REQUIREMENTS
2. UNLESS OTHERWISE SPECIFIED, TREES SHALL BE PLANTED NO LESS THAN 4' FROM CURBS, SIDEWALKS, UTILITY LINES, SCREENING WALLS AND OTHER STRUCTURES. THE CITY HAS FINAL APPROVAL FOR ALL TREE PLACEMENTS.
3. A MINIMUM THREE FEET (3) RADIUS AROUND A FIRE HYDRANT MUST REMAIN CLEAR OF LANDSCAPE.
4. THE AMERICAN STANDARD FOR NURSERY STOCK (ANSI Z60.1-2004) SPECIFICATIONS SHALL GOVERN PLANT QUALIFICATIONS, GRADES, AND STANDARDS.
5. TREE PLANTING SHALL COMPLY WITH DETAILS IN THE INTERNATIONAL SOCIETY OF ARBORICULTURE (ISA) STANDARDS.
6. A 2-3" LAYER OF MULCH SHALL BE PROVIDED AROUND THE BASE OF THE PLANTED TREE IN GRASS AREA. THE MULCH SHALL BE PULLED BACK 4" FROM THE TRUNK OF THE TREE.
7. TREE PITS SHALL BE TESTED FOR WATER PERCOLATION. IF WATER DOES NOT DRAIN OUT OF TREE PIT WITHIN 24 HOURS, THE TREE SHALL BE MOVED OR DRAINAGE SHALL BE PROVIDED.
8. ALL BEDS TO HAVE 3" OF COMPOSTED SOIL TILLED AND TURNED TO A DEPTH OF 6" MINIMUM.
9. ALL PLANT BEDS, NOT TOP-DRESSED WITH GRAVEL OR ROCK, SHALL BE TOP-DRESSED WITH A MINIMUM OF 3" OF HARDWOOD MULCH.
10. 4" METAL EDGING TO BE USED WHERE PLANTING BEDS MEET GRASS, AROUND ASIAN JASMINE, AND AROUND GRAVEL AREAS.
11. CONTRACTOR IS RESPONSIBLE FOR ASSURING ALL MATERIAL COUNTS ARE ACCURATE.

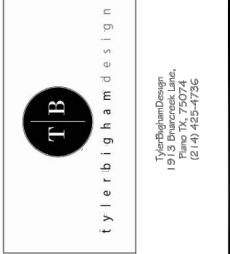
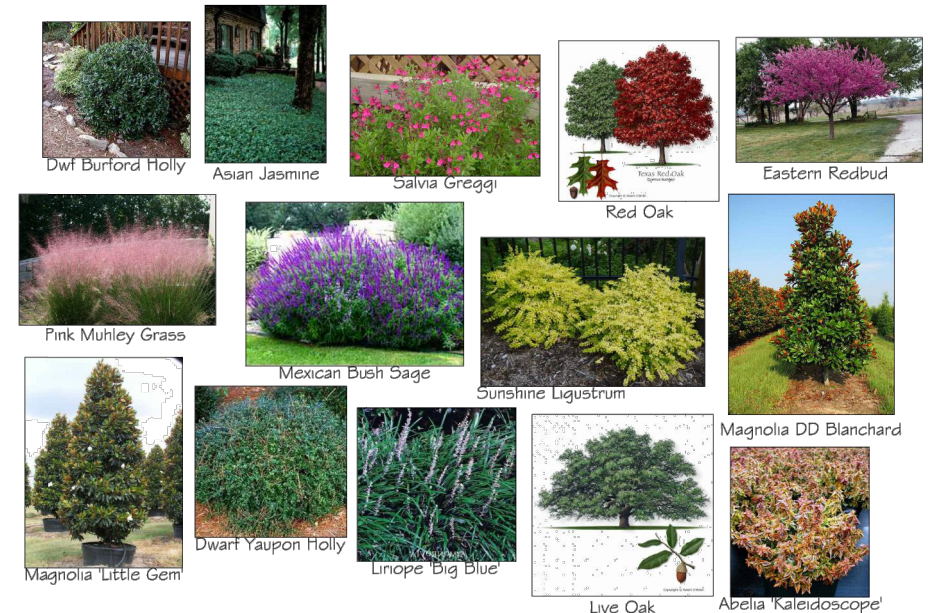
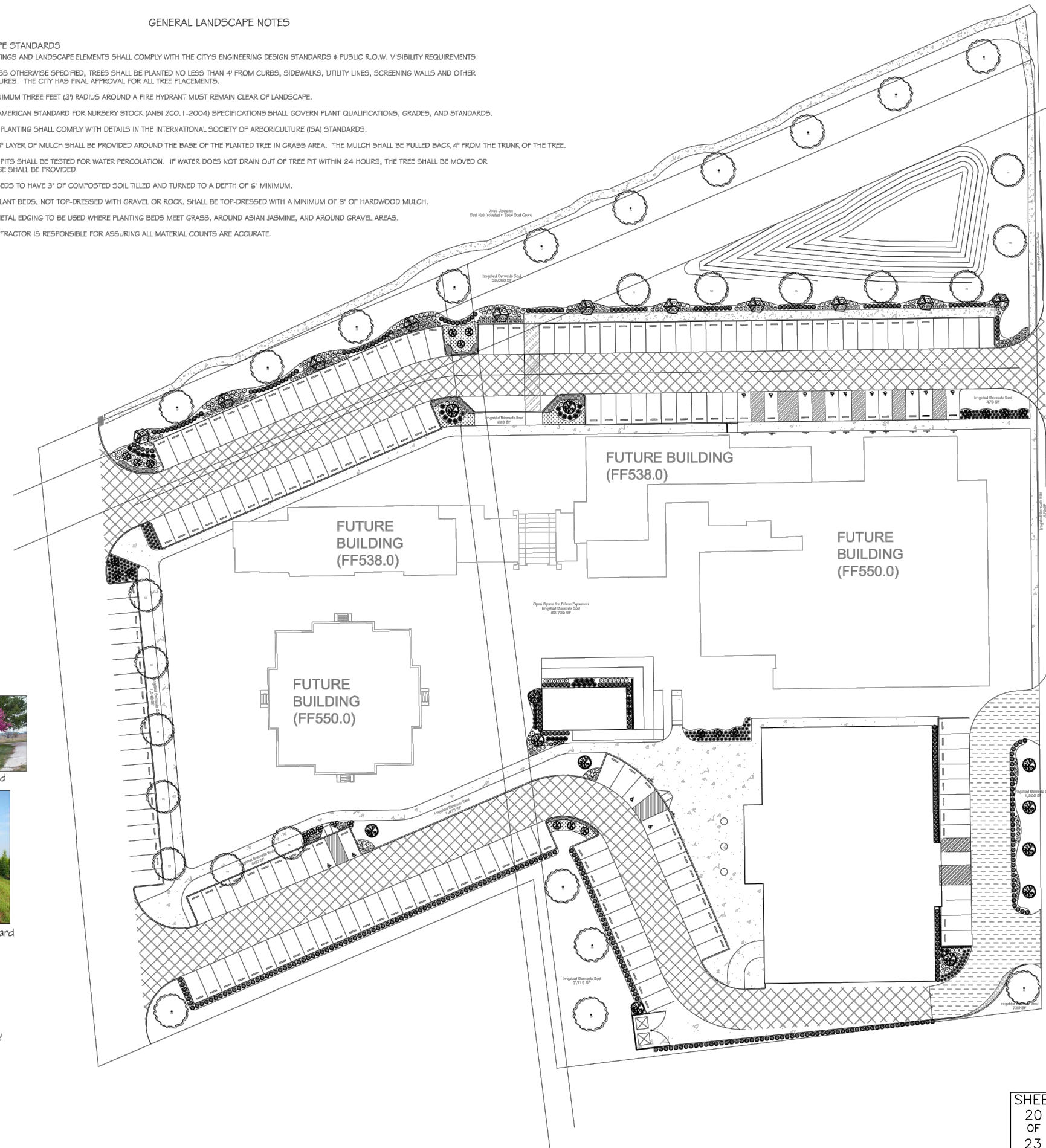

THESE PLANS ARE COPYRIGHTED AND ARE SUBJECT TO COPYRIGHT PROTECTION AS IN "ARCHITECTURAL WORK" UNDER SEC. 102 OF THE COPYRIGHT ACT, 17 U.S.C. AS AMENDED DECEMBER 1990 AND KNOWN AS ARCHITECTURAL WORKS COPYRIGHT PROTECTION ACT OF 1990. THE PROTECTION INCLUDES BUT IS NOT LIMITED TO THE OVERALL FORM AS WELL AS THE ARRANGEMENT AND COMPOSITION OF SPACES AND ELEMENTS OF THE DESIGN.

1212 Royal Parkway,  
Eules, TX

Notes:  
  
  
  
  
  
  
  
  
  
Date:  
December 30, 2020  
  
Drawn By:  
TB  
  
Scale:  
1" = 30' - 0"  
  
Dwg #:  
LS 100  
COPYRIGHT © 2020

SHEET  
20  
OF  
23



Water Source #1	
Meter Size	2 inch meter
Static Pressure	65 psi
Elevation Change	0 ft
Service Line Information	
Pipe Category	
Pipe Size	
Length	0 ft
Velocity	5 fps
Recommendations	
Maximum Recommended Flow	90 gpm
Available Working Pressure	53 psi

Water Source #2	
Meter Size	2 inch meter
Static Pressure	65 psi
Elevation Change	0 ft
Service Line Information	
Pipe Category	
Pipe Size	
Length	0 ft
Velocity	5 fps
Recommendations	
Maximum Recommended Flow	0 gpm
Available Working Pressure	53.5 psi

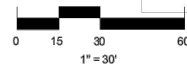

### Irrigation

Quantity	Symbol	Description	Pressure	Flow	Radius
<b>Sprinklers</b>					
18	●	Hunter 8H - SRS-04	30 psi	0.47 gpm	8 ft
3	●	Hunter 8Q - SRS-04	30 psi	0.24 gpm	8 ft
4	●	Hunter ES-515 - SRS-04	30 psi	0.65 gpm	15 x 5 ft
3	●	Hunter MP Left Strip - PROS-04-PRS30	30 psi	0.19 gpm	15 x 5 ft
4	●	Hunter MP Left Strip - Reduced - PROS-04-PRS30	30 psi	0.14 gpm	12 x 4 ft
3	●	Hunter MP Right Strip - PROS-04-PRS30	30 psi	0.19 gpm	15 x 5 ft
1	●	Hunter MP Right Strip - Reduced - PROS-04-PRS30	30 psi	0.14 gpm	12 x 4 ft
1	●	Hunter MP Side Strip - PROS-04-PRS30	30 psi	0.38 gpm	30 x 5 ft
1	●	Hunter MP Side Strip - Reduced - PROS-04-PRS30	30 psi	0.27 gpm	24 x 4 ft
2	●	Hunter MP1000 90° - PROS-04-PRS30	30 psi	0.16 gpm	12 ft
42	●	Hunter MP2000 180° - PROS-04-PRS30	30 psi	0.63 gpm	17 ft
1	●	Hunter MP2000 360° - PROS-04-PRS30	30 psi	1.27 gpm	17 ft
6	●	Hunter MP2000 90° - PROS-04-PRS30	30 psi	0.33 gpm	18 ft
96	●	Hunter MP3000 180° - PROS-04-PRS30	25 psi	1.44 gpm	25 ft
136	●	Hunter MP3000 360° - PROS-04-PRS30	30 psi	3.15 gpm	27 ft
16	●	Hunter MP3000 90° - PROS-04-PRS30	25 psi	0.69 gpm	25 ft
17	●	Hunter SS-530 - US-400	30 psi	1.3 gpm	30 x 5 ft
8	●	Rain Bird 10H - US-400	30 psi	0.79 gpm	10 ft
2	●	Rain Bird 10Q - US-400	30 psi	0.39 gpm	10 ft
1	●	Rain Bird 12F - US-400	30 psi	2.6 gpm	12 ft
8	●	Rain Bird 12H - US-400	30 psi	1.3 gpm	12 ft
10	●	Rain Bird 12Q - US-400	30 psi	0.65 gpm	12 ft
52	●	Rain Bird 1402	30 psi	0.5 gpm	0 ft
5	●	Rain Bird 15H - US-400	30 psi	1.85 gpm	15 ft
3	●	Rain Bird 15Q - US-400	30 psi	0.92 gpm	15 ft
4	●	Rain Bird 5H - US-400	30 psi	0.2 gpm	5 ft
2	●	Rain Bird 5Q - US-400	30 psi	0.1 gpm	5 ft
129	●	Rain Bird 8H - US-400	30 psi	0.52 gpm	8 ft
12	●	Rain Bird 8Q - US-400	30 psi	0.26 gpm	8 ft

Meters/Pumps	
1	2 inch meter

Backflow Assemblies	
1	Febco 850 - 2"

Control Valves	
38	Rain Bird 150-PGA Angle
1	Rain Bird 200-PGA Angle
4	Rain Bird XCZ-100-PRB-COM
5	Rain Bird XCZ-100-PRB-LC

Irrigation Accessories	
1	Miscellaneous 2 INCH Y-STRAINER
1	Nibco 2" isolation valve
1	Rain Bird ESP-LXD
1	Rain Bird RAIN/FREEZE SENSOR

Lateral Line Pipe	
4872 ft	Class 200 3/4"
3535 ft	Class 200 1"
645 ft	Class 200 1 1/4"
1235 ft	Class 200 1 1/2"

Mainline Pipe	
3760 ft	Class 200 2"

Sleeving	
368 ft	Class 315 1/2"
397 ft	Class 160 4"

Drip Tubing	
6458 ft	Rain Bird XFS-06-18

EACH VALVE TO HAVE RAINBIRD FD-101 TURF DECODER.

SURGE PROTECTION REQUIRED EVERY 500 FEET. SEE MANUFACTURER.

LSP-1 TURF LINE SURGE PROTECTION REQUIRED

REQUIRED 2 WIRE PATH  
SEE RAINBIRD INSTALL GUIDELINES

#### Sprinkler Zone Data

Zone #	Total Area	Total Flow	Precip Rate
2	2257.04 Sq/Ft	10.74 gpm	0.46 in/hr
3	3451.57 Sq/Ft	11.98 gpm	0.33 in/hr
4	6188.44 Sq/Ft	12.64 gpm	0.2 in/hr
5	5533.9 Sq/Ft	16.51 gpm	0.29 in/hr
6	7153.08 Sq/Ft	15.75 gpm	0.21 in/hr
7	5725.13 Sq/Ft	14.18 gpm	0.24 in/hr
8	6093.23 Sq/Ft	14.18 gpm	0.22 in/hr
9	5335.51 Sq/Ft	12.6 gpm	0.23 in/hr
10	6174.43 Sq/Ft	15.75 gpm	0.25 in/hr
11	8203.22 Sq/Ft	15.75 gpm	0.18 in/hr
12	5894.73 Sq/Ft	14.19 gpm	0.23 in/hr
13	7643.67 Sq/Ft	16.54 gpm	0.21 in/hr
14	40.59 Sq/Ft	6.5 gpm	15.42 in/hr
15	43.71 Sq/Ft	7 gpm	15.42 in/hr
16	12.49 Sq/Ft	2 gpm	15.42 in/hr
17	37.47 Sq/Ft	6 gpm	15.42 in/hr
22	914.53 Sq/Ft	16.01 gpm	1.69 in/hr
23	13664.58 Sq/Ft	31.5 gpm	0.22 in/hr
24	14761.63 Sq/Ft	33.08 gpm	0.22 in/hr
25	12953.47 Sq/Ft	28.35 gpm	0.21 in/hr
26	15700.53 Sq/Ft	32.94 gpm	0.2 in/hr
27	13277.63 Sq/Ft	31.51 gpm	0.23 in/hr
28	14689.81 Sq/Ft	31.5 gpm	0.21 in/hr
29	13424.49 Sq/Ft	31.23 gpm	0.22 in/hr
30	15421.81 Sq/Ft	31.5 gpm	0.2 in/hr
31	13302.16 Sq/Ft	31.51 gpm	0.23 in/hr
32	10583.7 Sq/Ft	31.44 gpm	0.29 in/hr
33	12896.95 Sq/Ft	28.67 gpm	0.21 in/hr
34	8935.03 Sq/Ft	24.93 gpm	0.27 in/hr
35	8964.76 Sq/Ft	25.01 gpm	0.27 in/hr
36	952.76 Sq/Ft	13.78 gpm	1.39 in/hr
37	865.89 Sq/Ft	13 gpm	1.45 in/hr
38	1172.13 Sq/Ft	17.3 gpm	1.42 in/hr
39	1227.43 Sq/Ft	17.18 gpm	1.35 in/hr
40	807.85 Sq/Ft	14.58 gpm	1.74 in/hr
41	1007.88 Sq/Ft	14.56 gpm	1.39 in/hr
42	906.97 Sq/Ft	12.88 gpm	1.37 in/hr
43	4118.32 Sq/Ft	13.02 gpm	0.3 in/hr
44	3719.58 Sq/Ft	14.58 gpm	0.38 in/hr
45	2043.33 Sq/Ft	11.34 gpm	0.53 in/hr
46	830.78 Sq/Ft	24.4 gpm	2.83 in/hr

#### Drip Zone Data

Zone #	Total Area	Total Flow	Precip Rate
17	2042.59 Sq/Ft	544.2 gph	0.43 in/hr
18	1776.21 Sq/Ft	473.4 gph	0.43 in/hr
19	1396.42 Sq/Ft	370.8 gph	0.43 in/hr
20	2194.53 Sq/Ft	583.8 gph	0.43 in/hr
21	2276.07 Sq/Ft	605.4 gph	0.43 in/hr

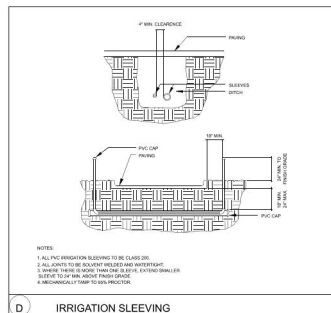
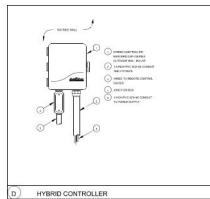
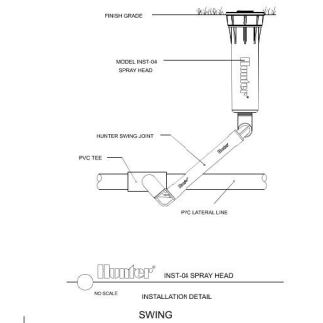
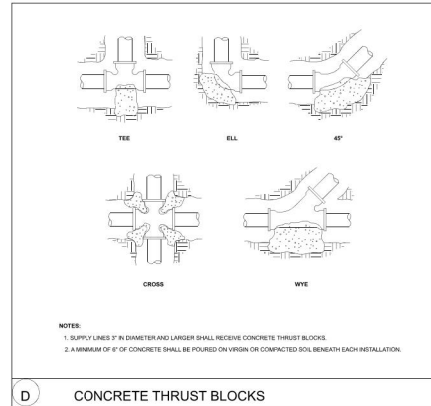
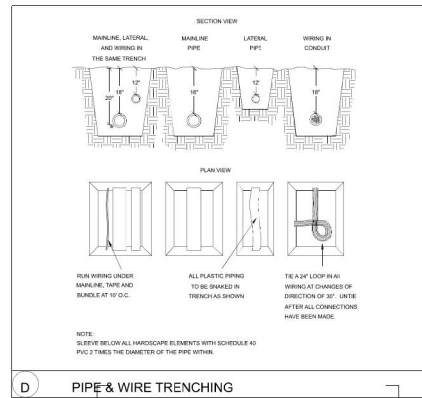
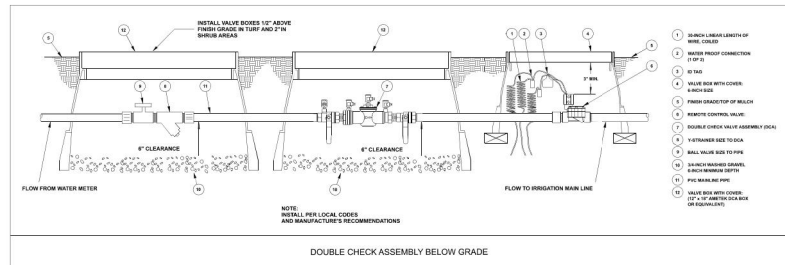

1	1 1/2"	10	1 1/2"	19	1"	28	1 1/2"	37	1 1/2"	46	1 1/2"
10.74	GPM	15.75	GPM	7.59	GPM	31.5	GPM	13	GPM	24.4	GPM
2	1 1/2"	11	1 1/2"	20	1"	29	1 1/2"	38	1 1/2"		
11.98	GPM	14.19	GPM	9.73	GPM	31.23	GPM	17.3	GPM		
3	1 1/2"	12	1 1/2"	21	1"	30	1 1/2"	39	1 1/2"		
12.64	GPM	16.54	GPM	8.11	GPM	31.5	GPM	17.18	GPM		
4	1 1/2"	13	1"	22	1 1/2"	31	1 1/2"	40	1 1/2"		
16.51	GPM	6.5	GPM	16.01	GPM	31.51	GPM	14.58	GPM		
5	1 1/2"	14	1"	23	1 1/2"	32	1 1/2"	41	1 1/2"		
15.75	GPM	7	GPM	31.5	GPM	31.44	GPM	14.56	GPM		
6	1 1/2"	15	1"	24	1 1/2"	33	1 1/2"	42	1 1/2"		
14.18	GPM	5.5	GPM	33.08	GPM	28.67	GPM	12.88	GPM		
7	1 1/2"	16	1"	25	1 1/2"	34	1 1/2"	43	1 1/2"		
14.18	GPM	6	GPM	28.35	GPM	24.93	GPM	13.02	GPM		
8	1 1/2"	17	1"	26	1 1/2"	35	1 1/2"	44	1 1/2"		
12.6	GPM	9.07	GPM	32.94	GPM	25.01	GPM	14.58	GPM		
9	1 1/2"	18	1"	27	1 1/2"	36	1 1/2"	45	1 1/2"		
15.75	GPM	7.89	GPM	31.51	GPM	13.78	GPM	11.34	GPM		

**Sprinkler Zone Data**

Zone #	Total Area	Total Flow	Precip Rate
1	2257.04 Sq/Ft	10.74 gpm	0.46 in/hr
2	3451.57 Sq/Ft	11.98 gpm	0.33 in/hr
3	6188.44 Sq/Ft	12.64 gpm	0.2 in/hr
4	5533.9 Sq/Ft	16.51 gpm	0.29 in/hr
5	7183.08 Sq/Ft	15.75 gpm	0.21 in/hr
6	5725.13 Sq/Ft	14.18 gpm	0.24 in/hr
7	6093.23 Sq/Ft	14.18 gpm	0.22 in/hr
8	5335.51 Sq/Ft	12.6 gpm	0.23 in/hr
9	6174.43 Sq/Ft	15.75 gpm	0.25 in/hr
10	8203.22 Sq/Ft	15.75 gpm	0.18 in/hr
11	5864.73 Sq/Ft	14.19 gpm	0.23 in/hr
12	7643.67 Sq/Ft	16.54 gpm	0.21 in/hr
13	40.59 Sq/Ft	6.5 gpm	15.42 in/hr
14	43.71 Sq/Ft	7 gpm	15.42 in/hr
15	12.49 Sq/Ft	2 gpm	15.42 in/hr
16	37.47 Sq/Ft	6 gpm	15.42 in/hr
22	914.53 Sq/Ft	16.01 gpm	1.69 in/hr
23	13664.58 Sq/Ft	31.5 gpm	0.22 in/hr
24	14761.63 Sq/Ft	33.08 gpm	0.22 in/hr
25	12963.47 Sq/Ft	28.35 gpm	0.21 in/hr
26	15700.53 Sq/Ft	32.94 gpm	0.2 in/hr
27	13277.63 Sq/Ft	31.51 gpm	0.23 in/hr
28	14689.81 Sq/Ft	31.5 gpm	0.21 in/hr
29	13424.49 Sq/Ft	31.23 gpm	0.22 in/hr
30	15421.81 Sq/Ft	31.5 gpm	0.2 in/hr
31	13302.16 Sq/Ft	31.51 gpm	0.23 in/hr
32	10583.7 Sq/Ft	31.44 gpm	0.29 in/hr
33	12896.95 Sq/Ft	28.67 gpm	0.21 in/hr
34	8935.03 Sq/Ft	24.93 gpm	0.27 in/hr
35	8964.76 Sq/Ft	25.01 gpm	0.27 in/hr
36	952.76 Sq/Ft	13.78 gpm	1.39 in/hr
37	865.89 Sq/Ft	13 gpm	1.45 in/hr
38	1172.13 Sq/Ft	17.3 gpm	1.42 in/hr
39	1227.43 Sq/Ft	17.18 gpm	1.35 in/hr
40	807.85 Sq/Ft	14.58 gpm	1.74 in/hr
41	1007.68 Sq/Ft	14.56 gpm	1.39 in/hr
42	906.97 Sq/Ft	12.88 gpm	1.37 in/hr
43	4118.32 Sq/Ft	13.02 gpm	0.3 in/hr
44	3719.58 Sq/Ft	14.58 gpm	0.38 in/hr
45	2043.33 Sq/Ft	11.34 gpm	0.53 in/hr
46	830.78 Sq/Ft	24.4 gpm	2.83 in/hr

**Drip Zone Data**

Zone #	Total Area	Total Flow	Precip Rate
17	2042.59 Sq/Ft	544.2 gph	0.43 in/hr
18	1776.21 Sq/Ft	473.4 gph	0.43 in/hr
19	1396.42 Sq/Ft	370.8 gph	0.43 in/hr
20	2194.53 Sq/Ft	583.8 gph	0.43 in/hr
21	2276.07 Sq/Ft	605.4 gph	0.43 in/hr

**Water Source #1**

Meter Size	2 inch meter
Static Pressure	65 psi
Elevation Change	0 ft

**Service Line Information**

Pipe Category	
Pipe Size	
Length	0 ft
Velocity	5 fps

**Recommendations**

Maximum Recommended Flow	90 gpm
Available Working Pressure	53 psi

**Water Source #2**

Meter Size	
Static Pressure	65 psi
Elevation Change	0 ft

**Service Line Information**

Pipe Category	
Pipe Size	
Length	0 ft
Velocity	5 fps

**Recommendations**

Maximum Recommended Flow	0 gpm
Available Working Pressure	58.5 psi

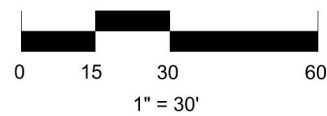

Luminaire Schedule							
Symbol	Qty	Label	Arrangement	LMF	Lum. Lumens	Lum. Watts	Part Number
□	2	T2	SINGLE	1.000	21902	215	OSQ-A-NM-2ME-T-40K-_-_- w/OSQ-DA_-_-
□	10	T4	SINGLE	1.000	21902	166	OSQ-A-NM-4ME-T-40K-_-_- w/OSQ-DA_-_-
□	3	X3	SINGLE	1.000	2490	72	XSPW-B-WM-3ME-2L-40K-_-_-

Calculation Summary (Footcandles calculated using initial lumen values @ 25°C)						
Label	Units	Avg	Max	Min	Avg/Min	Max/Min
CalcPts	Fc	0.78	5.4	0.0	N.A.	N.A.
PAVED AREA	Fc	1.80	5.4	0.3	6.00	18.00

Pole Fixture Height: 25' AFG (22' pole + 3' base)

Pole Schedule  
 (12) SSS-4-11-22-CW-BS-1D-C\_-\_- (22' X 4" X 11ga STEEL SQUARE POLE)  
 Proposed poles meet 130 MPH sustained winds.

Additional Equipment:  
 (12) OSQ-DA\_-\_- (Direct Arm Mount)

\*\*\* CUSTOMER TO VERIFY ORDERING INFORMATION AND CATALOGUE NUMBER PRIOR TO PLACING ORDER \*\*\*

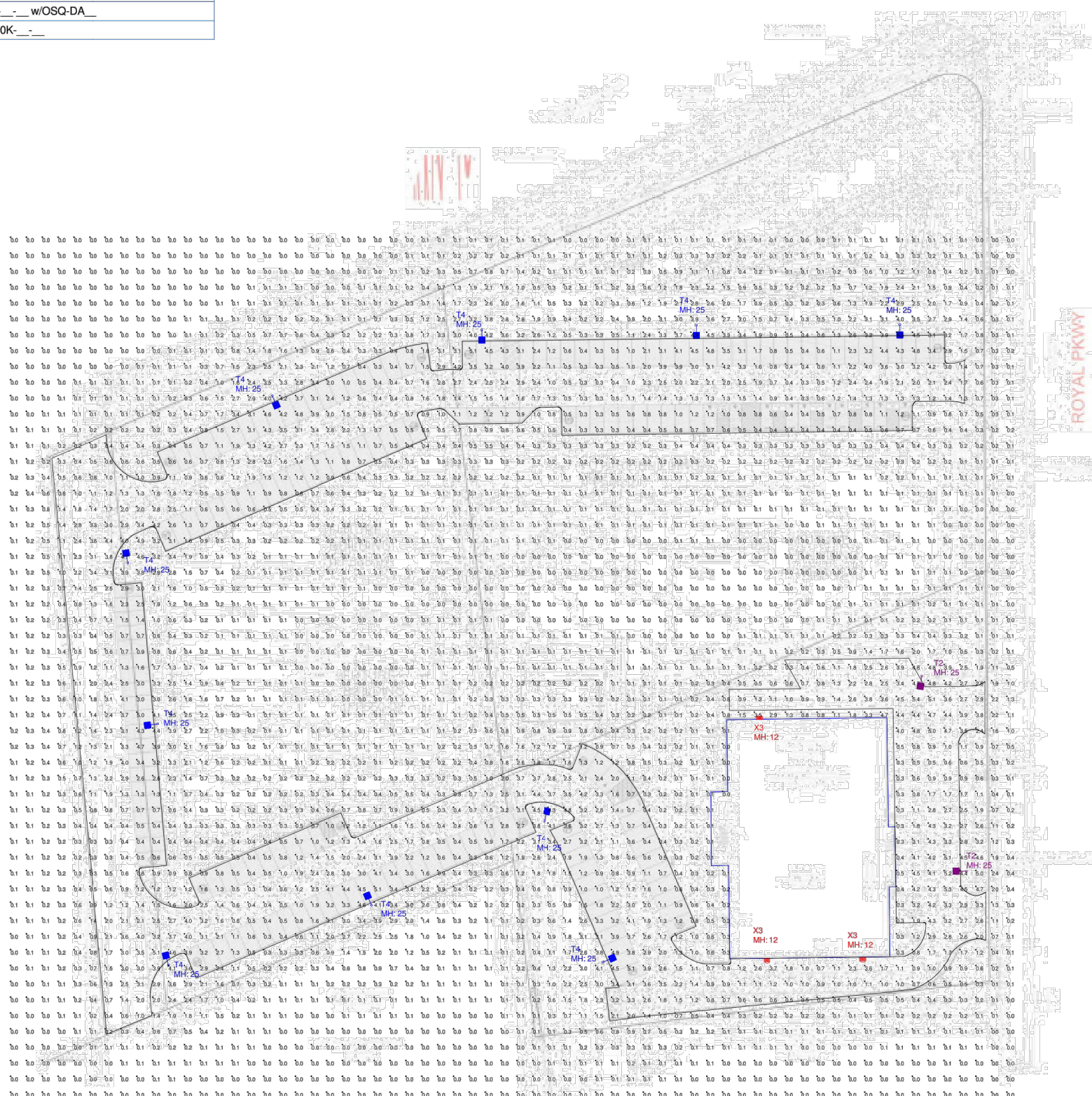

SHEET  
23  
OF  
23

**CREE LIGHTING**  
 A COMPANY OF IDEAL INDUSTRIES, INC.  
 9201 Washington Ave, Racine, WI 53406 https://creelighting.com - (800) 236-6800

Illumination results shown on this lighting design are based on project parameters provided to Cree Lighting used in conjunction with luminaire test procedures conducted under laboratory conditions. Actual project conditions differing from these design parameters may affect field results. The customer is responsible for verifying dimensional accuracy along with compliance with any applicable electrical, lighting or energy codes.

Project Name: NCSC Temple 1212 Royal Parkway Eules, TX 76040  
 SR-34013 || Footcandles calculated at grade || Filename: 201215OC1CIS.AGI

Layout By:  
Chris Schlitz  
Date: 12/15/2020

Scale 1" = 40'  
 0 80 160

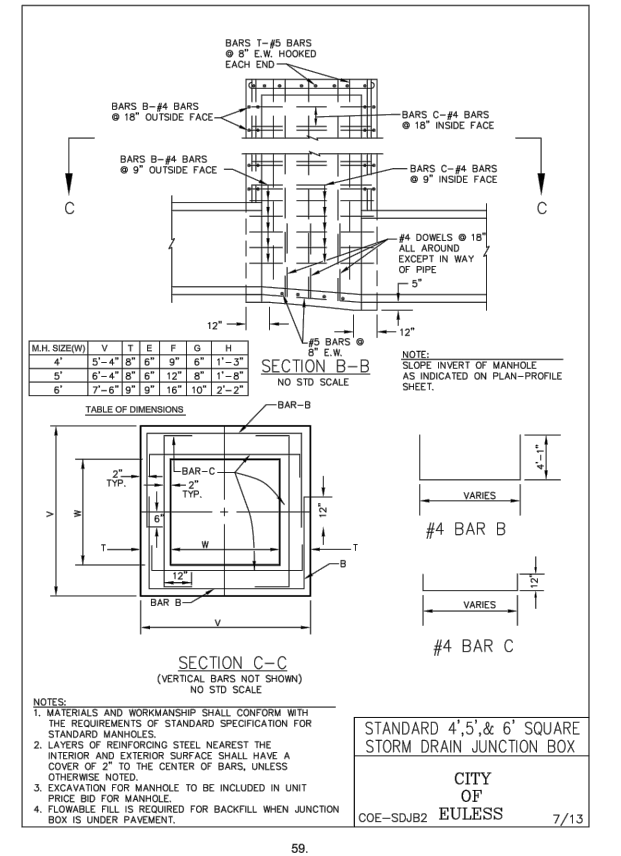
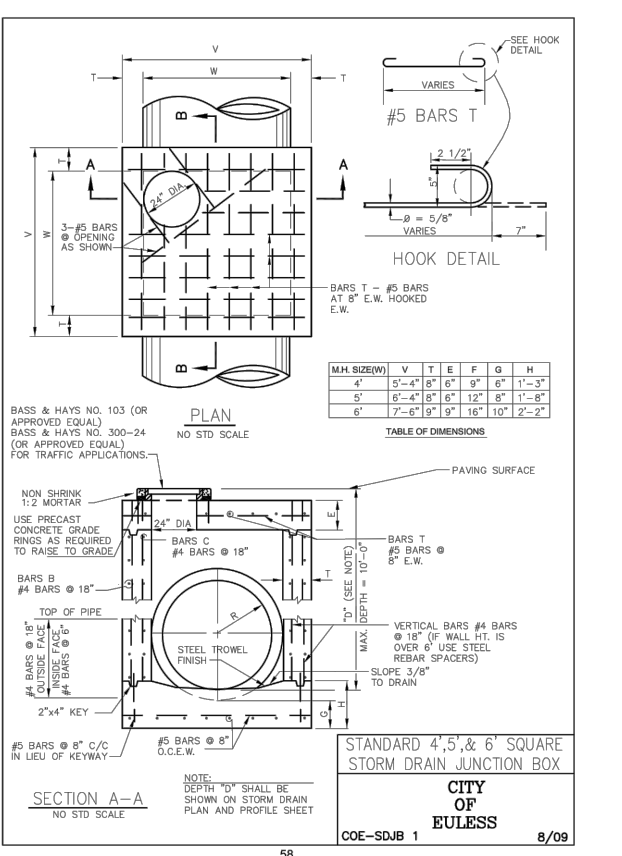
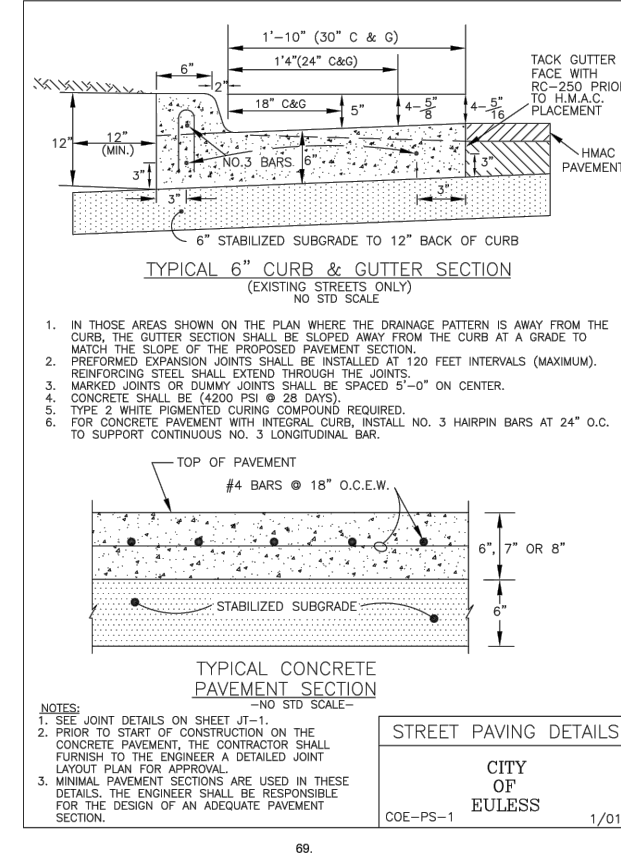
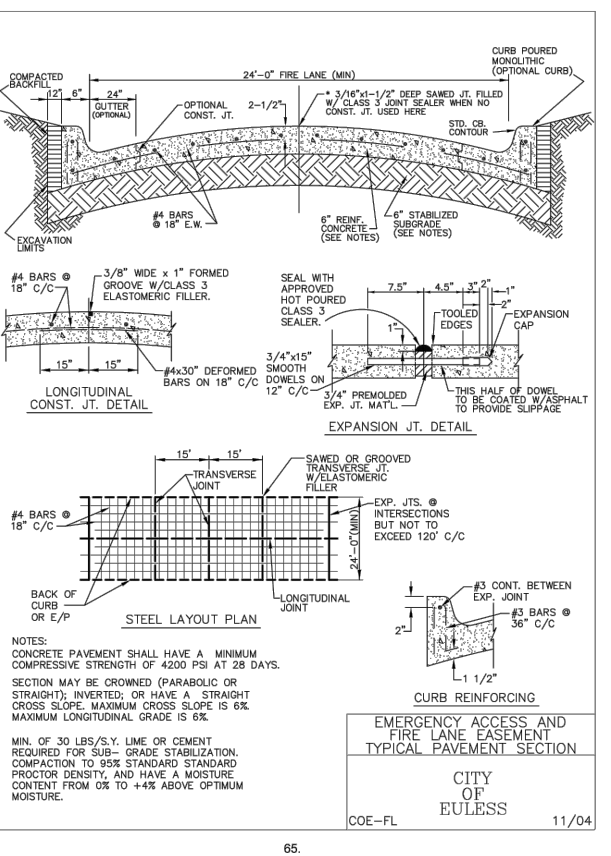
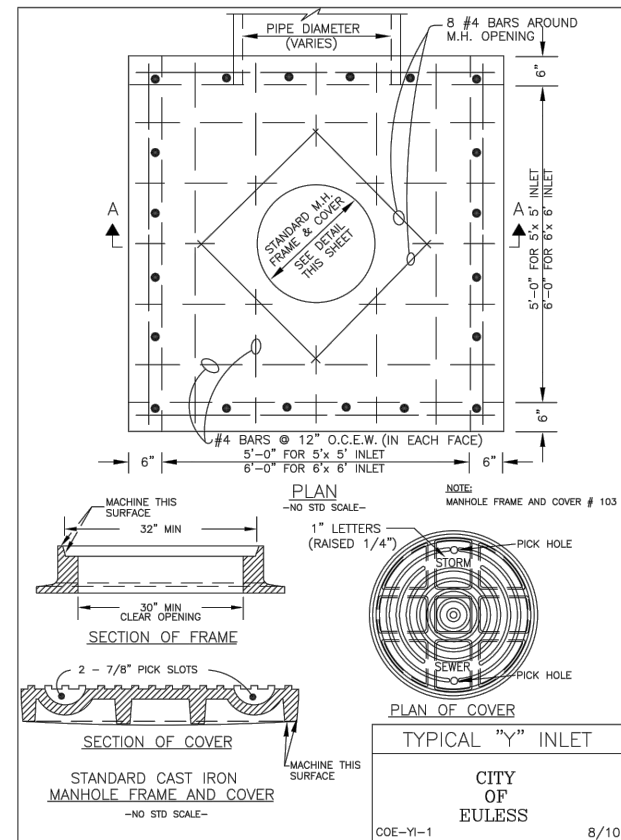
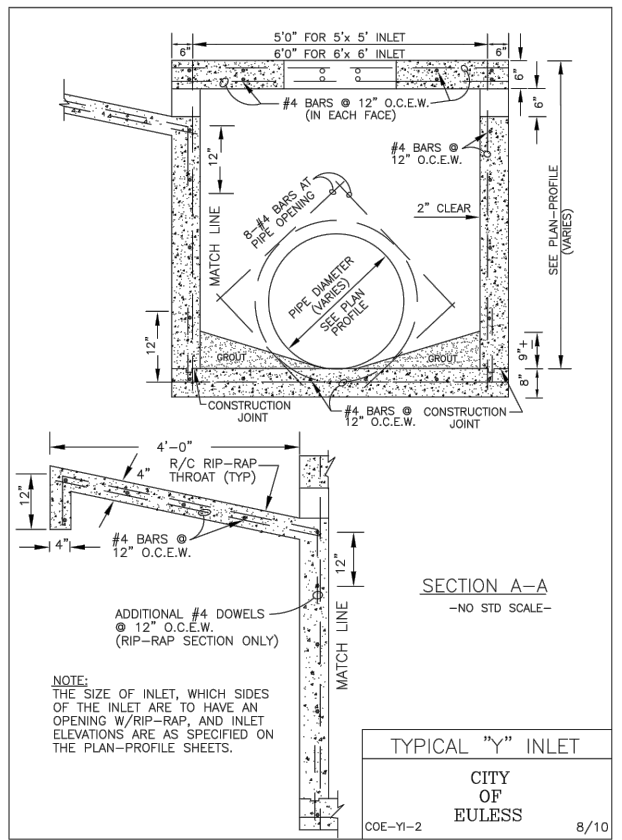
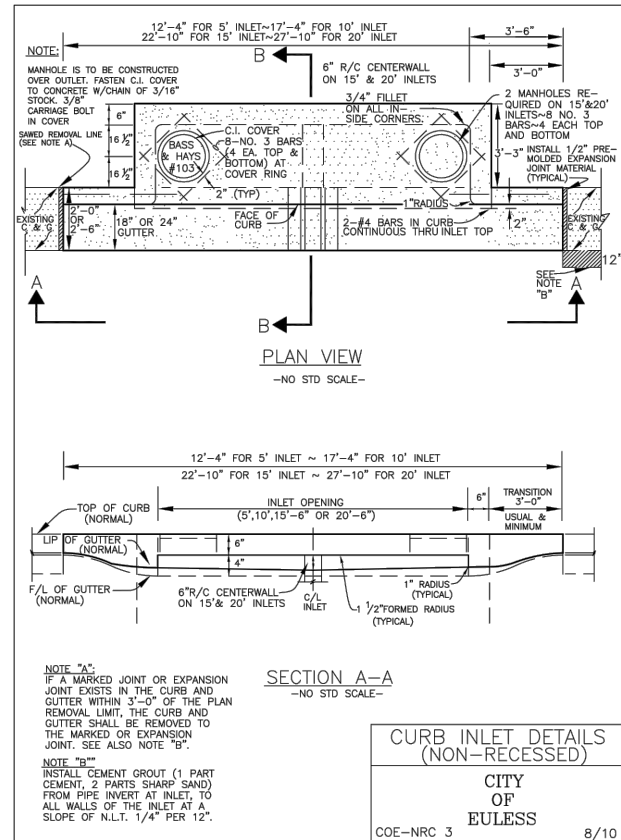
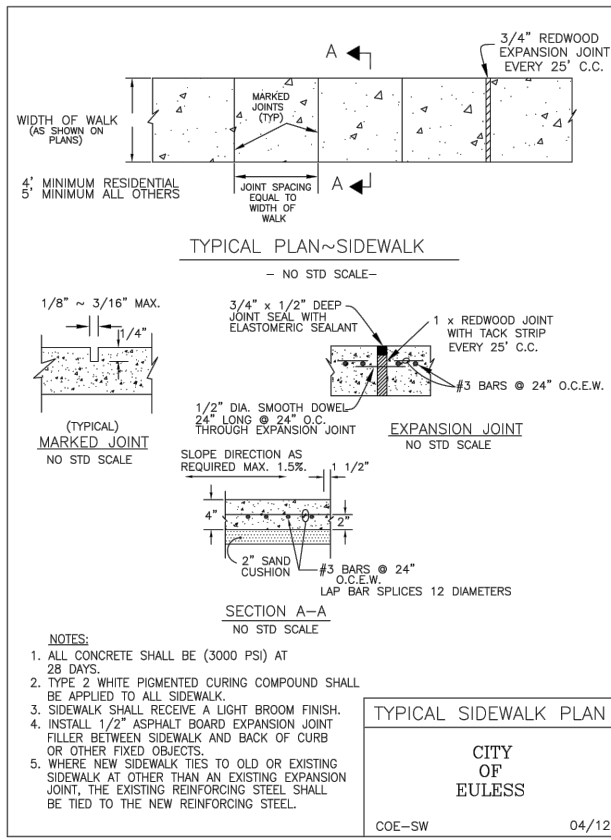

no.	revision	by	date

CIVIL ENGINEERING  
202 REPUBLIC LN  
EULESS, TX 76040  
PH: (972) 523-5493  
TBPE: F-19293

CIVIL ENGINEERING  
F-19293

scale  
horiz  
N/A  
vert  
N/A  
date  
MAY 2021



**PRELIMINARY PLAN**  
For Review Only  
This document is released for the purpose of interim review and markup under the authority of OM GHARTY CHHETRI, P.E. Licence No: 106562 on 5/6/21. This document is not to be used for construction, bidding or permit purposes.

STANDARD DETAILS  
**NEPALI CULTURAL AND SPIRITUAL CENTER**  
PHASE-I  
1212 ROYAL PARKWAY, EULESS TEXAS 76040

PROJECT NO.  
JN 1120



- WATER LINE GATE VALVE SPECIFICATIONS**
- ALL WATER LINE GATE VALVES IN THE CITY OF EULESS SHALL MEET OR EXCEED AWWA GATE VALVE STANDARD C-515, LATEST REVISION.
  - ALL GATE VALVES SHALL BE OF THE RESILIENT SEATED WEDGE TYPE, FUSION BONDED EPOXY COATED TO AWWA C-550, DUCTILE IRON BODY DESIGN.
  - ALL GATE VALVES SHALL BE RATED FOR ZERO LEAKAGE AT 200 PSI WATER WORKING PRESSURE AND HAVE A 400 PSI HYDROSTATIC TEST FOR STRUCTURAL SOUNDNESS FOR 4-INCH THROUGH 12-INCH DIAMETER. (ALL TESTING SHALL BE CONDUCTED IN ACCORDANCE WITH AWWA C-509).
  - GATE VALVES SHALL BE FURNISHED WITH TYPE OF END CONNECTION SPECIFIED AS FOLLOWS: 125# ANSI FLANGE DRILLING, OR MECHANICAL JOINT PER AWWA C-111.
  - STEMS SHALL BE MANGANESE BRONZE HAVING A MINIMUM TENSILE STRENGTH OF 60,000 PSI, A MINIMUM YIELD OF 20,000 PSI.
  - BOLTS SHALL BE ELECTRO-ZINC PLATED STEEL WITH "T" OR HEX HEADS AS SPECIFIED AND HEX NUTS IN ACCORDANCE WITH ASTM A-307.
  - VALVES SHALL BE OF THE NON-RISING STEM TYPE (NRS).
  - NRS STEM THRUST COLLARS SHALL BE CAST INTEGRAL WITH THE STEM AND MACHINED TO SIZE. A STAINLESS STEEL THRUST BEARING SHALL BE IN INCORPORATED TO OPTIMIZE OPERATING TORQUES.
  - NRS VALVES SHALL BE FURNISHED WITH O-RING STEM SEALS USING TWO O-RINGS LOCATED ABOVE AND ONE O-RING BELOW THE THRUST COLLAR. O-RINGS SHALL BE SET IN GROOVES IN THE STEM, THE O-RING GROOVE SHALL NOT BE LESS THAN THE ROOT DIAMETER OF THE STEM THREADS.
  - THE INTERNAL AND EXTERNAL IRON SURFACES OF THE VALVE BODY AND BONNET SHALL BE COATED WITH FUSION BONDED EPOXY TO AWWA C-550 STANDARDS. GATES FOR ALL VALVE SIZES SHALL BE COMPLETELY ENCAPSULATED IN RUBBER INCLUDING STEM BORE, BE FIELD REPLACABLE AND PROVIDE A DUAL SEAL ON THE MATING BODY SEAT.
  - VALVES SHALL BE CAPABLE OF INSTALLATION IN ANY POSITION WITH RATED SEALING IN BOTH DIRECTIONS.
  - RUBBER SEATS OF SPECIALLY COMPOUNDED SBR MATERIAL SHALL BE UTILIZED AND BE CAPABLE OF SEALING UNDER NORMAL CONDITIONS.
  - THE VALVE BODY SHALL HAVE INTEGRAL GUIDES ENGAGING INTEGRAL LUGS IN THE GATE IN A TONGUE AND GROOVE MANNER, SUPPORTING THE GATE THROUGHOUT THE ENTIRE OPEN/CLOSE TRAVEL.
  - THE INSIDE AND OUTSIDE OF VALVE BODY, BONNET AND SEAL PLATE SHALL BE COATED, MINIMUM 3-5 MILS, WITH FUSION BONDED EPOXY MEETING AWWA C-550, LATEST REVISION.
  - MARKING SHALL BE IN ACCORDANCE WITH AWWA C-515 STANDARDS, TO INCLUDE THE NAME OF MANUFACTURER, THE YEAR OF MANUFACTURING, MAXIMUM WORKING PRESSURE AND SIZE OF VALVE.
  - RESILIENT SEATED GATE VALVES SHALL BE COVERED BY TEN YEAR LIMITED WARRANTY AGAINST DEFECTIVE MATERIALS OR WORKMANSHIP.
  - ALL BOLTS, GASKETS, GLANDS, RINGS AND OTHER ACCESSORIES SHALL BE DELIVERED WITH EACH VALVE.
  - ALL RESILIENT SEATED GATE VALVES SHALL BE LEFT TURN TO OPEN (L.O).

THE MANUFACTURER SHALL HAVE A RELIABLE AND REPUTABLE DEALER WITHIN 25 MILES OF THE CITY OF EULESS AND MAINTAINS IN STOCK THE SPECIFIED VALVES, ALL ATTACHMENTS AND REPAIR KITS AVAILABLE IN 24 HOURS OR LESS.

**APPROVED GATE VALVES**  
 M & H - STYLE 3067  
 AMERICAN DARLING - CRS 80 SERIES  
 MULLER - 2360 SERIES  
 AMERICAN FLOW CONTROL (AFC) 2500 SERIES

**GATE VALVE SPECIFICATIONS**  
 CITY OF EULESS  
 COE-GV-1 01/15

4.

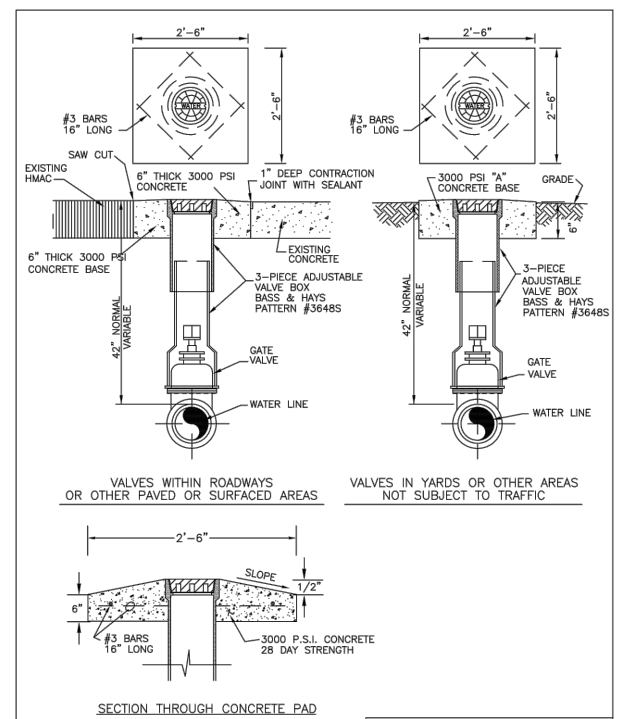

**VALVE PAD DETAILS**  
 CITY OF EULESS  
 COE-GV-3 2/99

6.

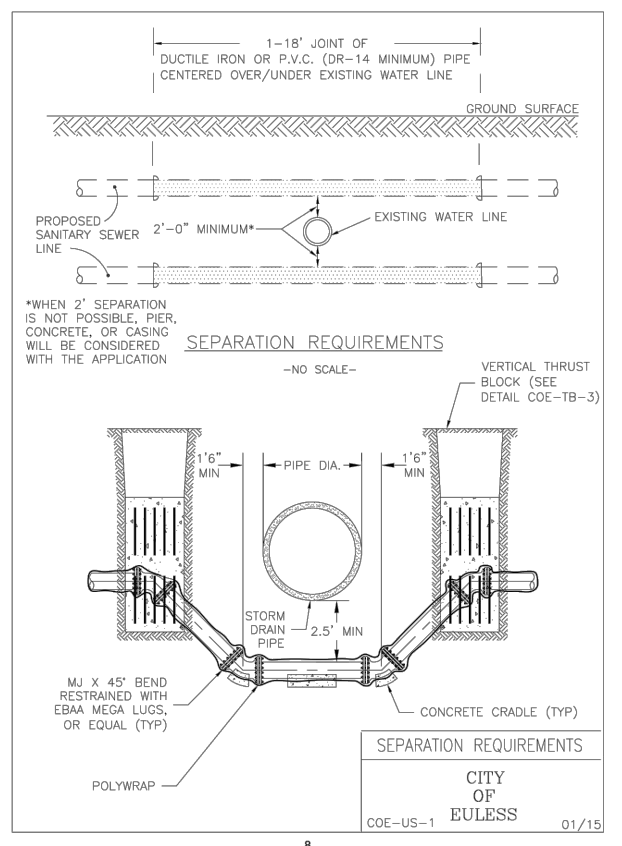

**SEPARATION REQUIREMENTS**  
 CITY OF EULESS  
 COE-US-1 01/15

8.

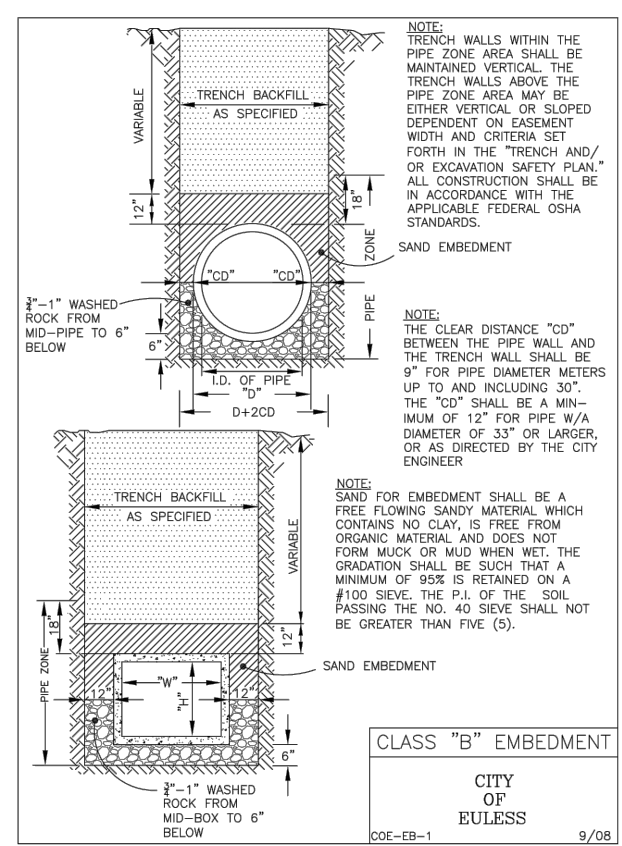

**CLASS "B" EMBEDMENT**  
 CITY OF EULESS  
 COE-EB-1 9/08

64.

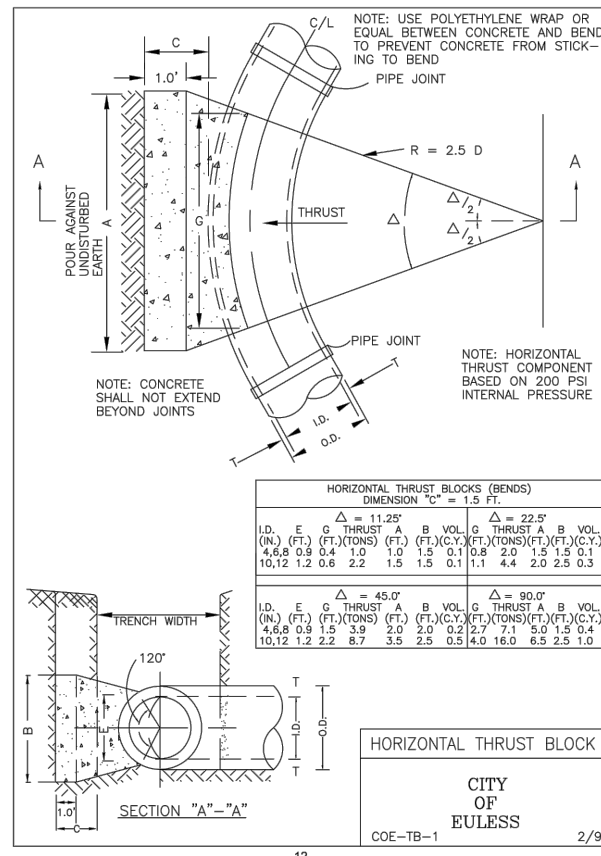

**HORIZONTAL THRUST BLOCK**  
 CITY OF EULESS  
 COE-TB-1 2/99

12.

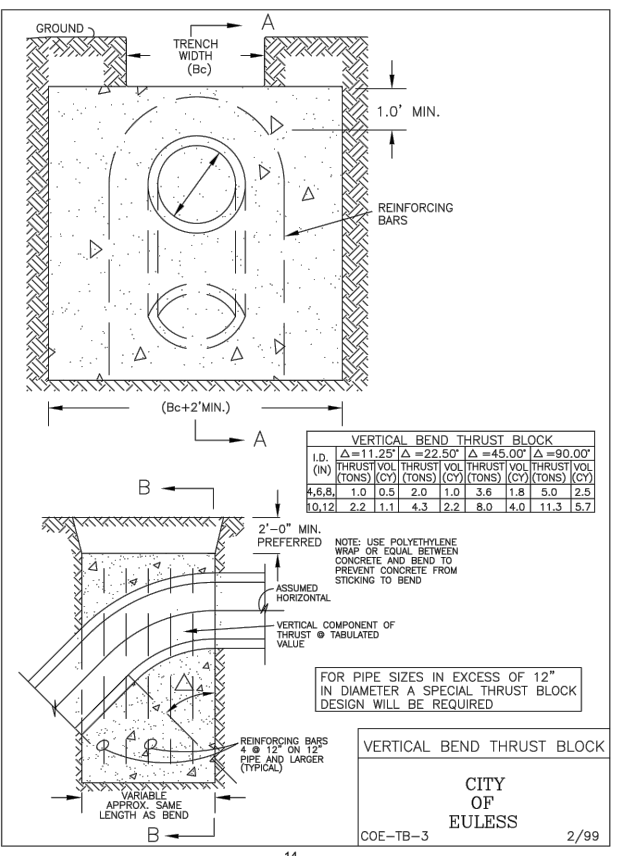

**VERTICAL BEND THRUST BLOCK**  
 CITY OF EULESS  
 COE-TB-3 2/99

14.

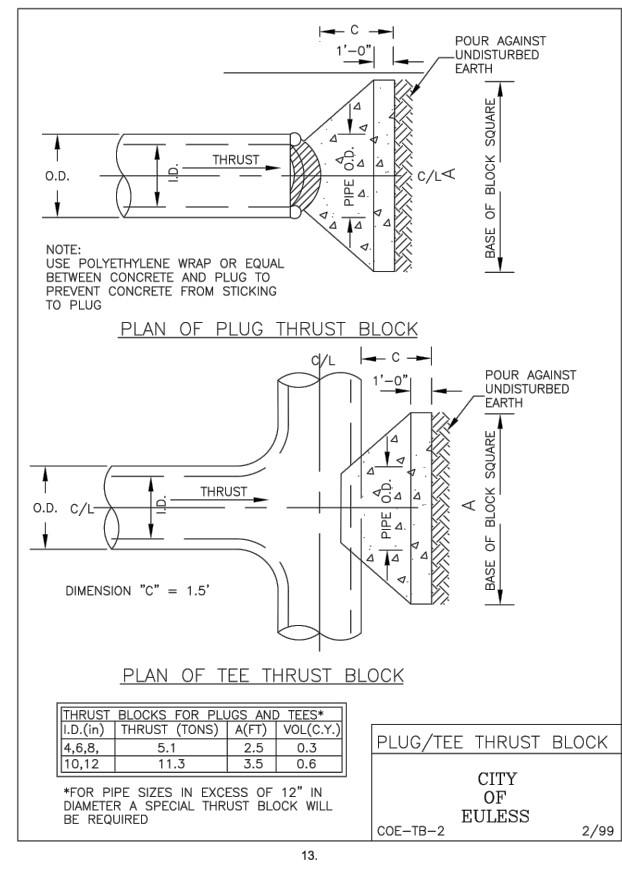

**PLUG/TEE THRUST BLOCK**  
 CITY OF EULESS  
 COE-TB-2 2/99

13.

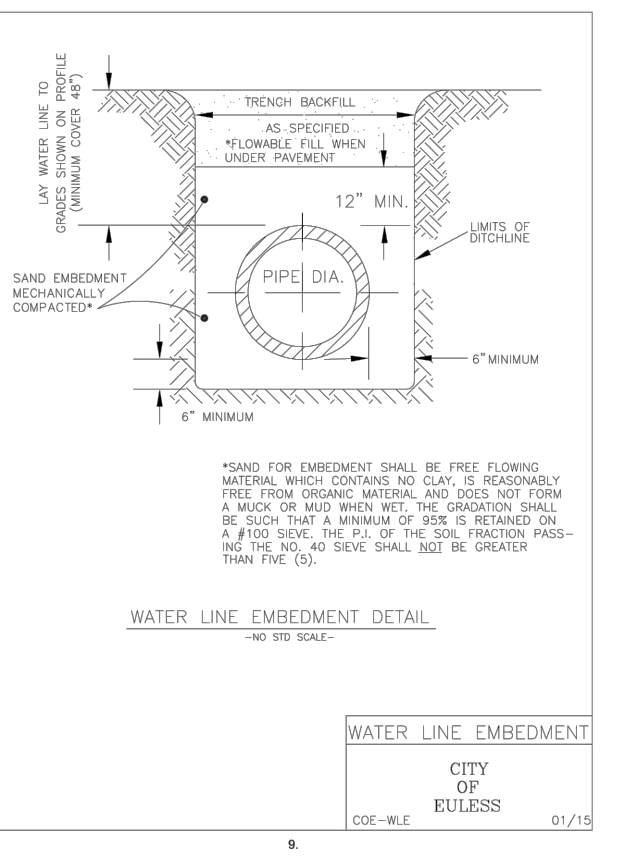

**WATER LINE EMBEDMENT**  
 CITY OF EULESS  
 COE-WLE 01/15

9.

no.	revision	by	date

iCIVIL ENGINEERING  
 202 REPUBLIC LN  
 EULESS, TX 76040  
 PH: (972) 523-5493  
 TBPE: F-19293

CIVIL ENGINEERING F-19293

scale  
 horiz N/A  
 vert N/A  
 date  
 MAY 2021



**PRELIMINARY PLAN**  
 For Review Only  
 This document is released for the purpose of interim review and markup under the authority of OM GHARTY CHHETRI, P.E. License No: 106562 on 5/6/21. This document is not to be used for construction, bidding or permit purposes.

STANDARD DETAILS  
**NEPALI CULTURAL AND SPIRITUAL CENTER PHASE-1**  
 1212 ROYAL PARKWAY, EULESS TEXAS 76040

PROJECT NO.  
 JN 1120

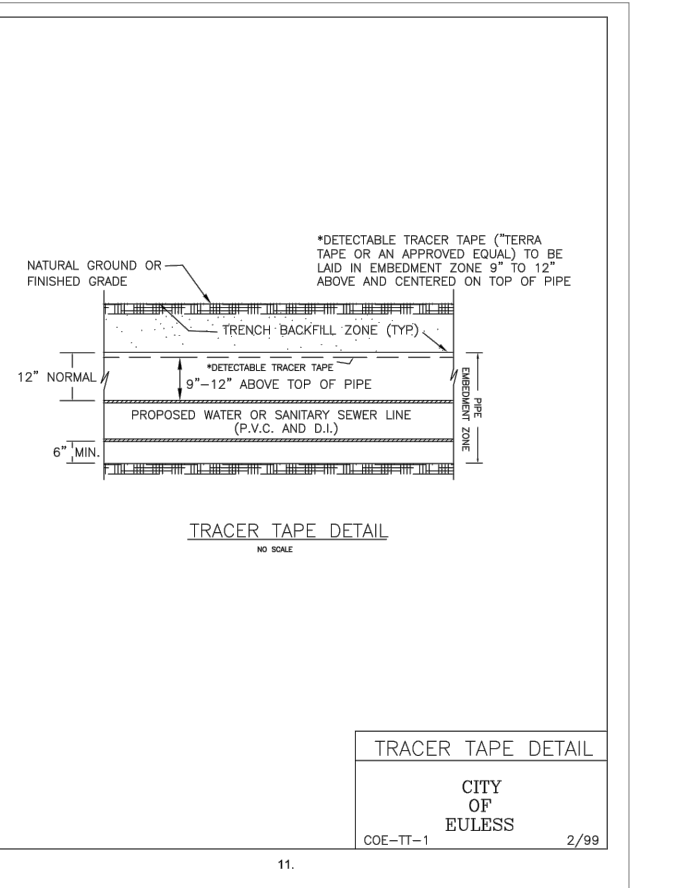
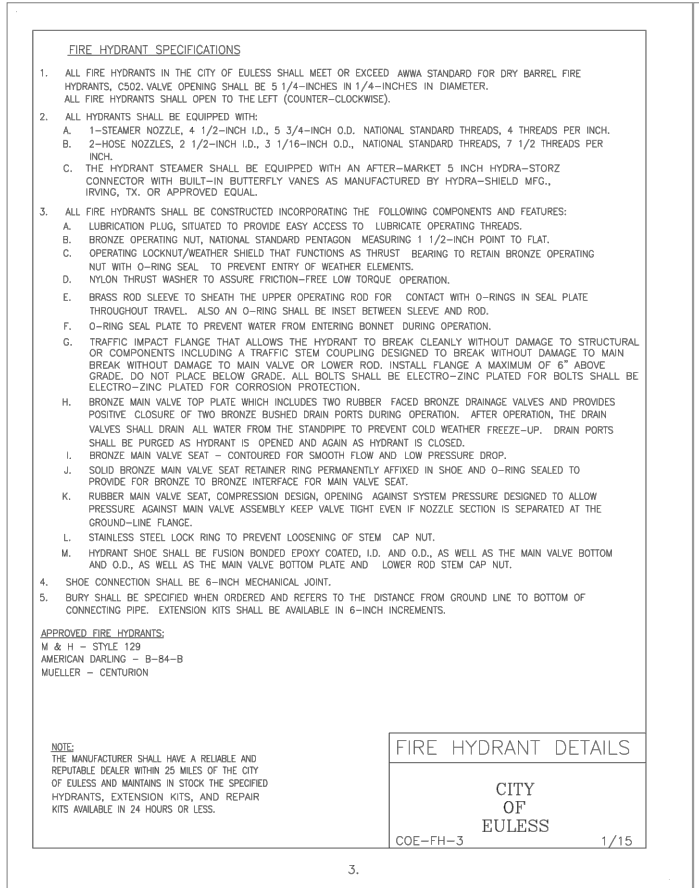
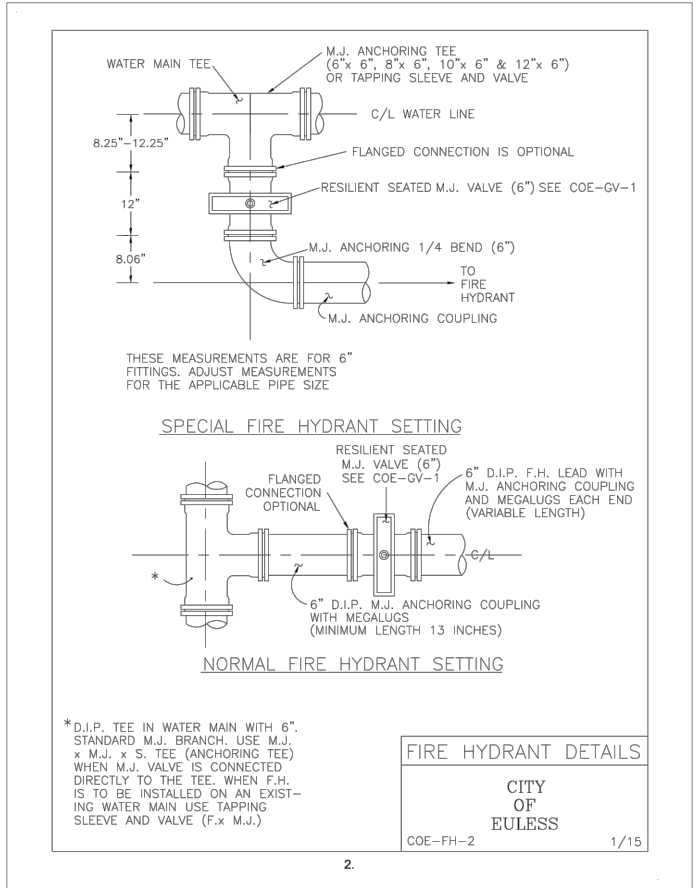
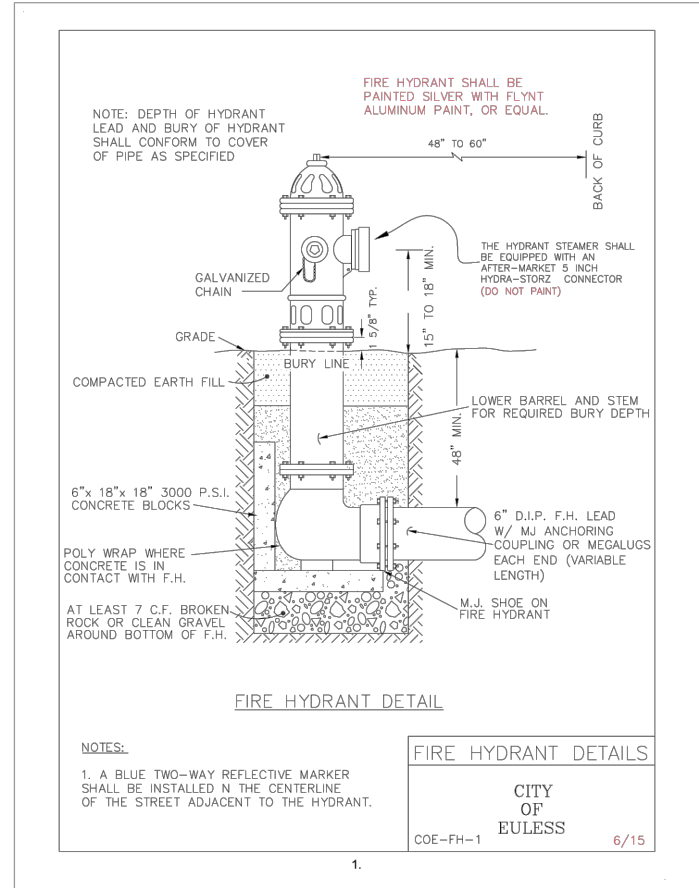
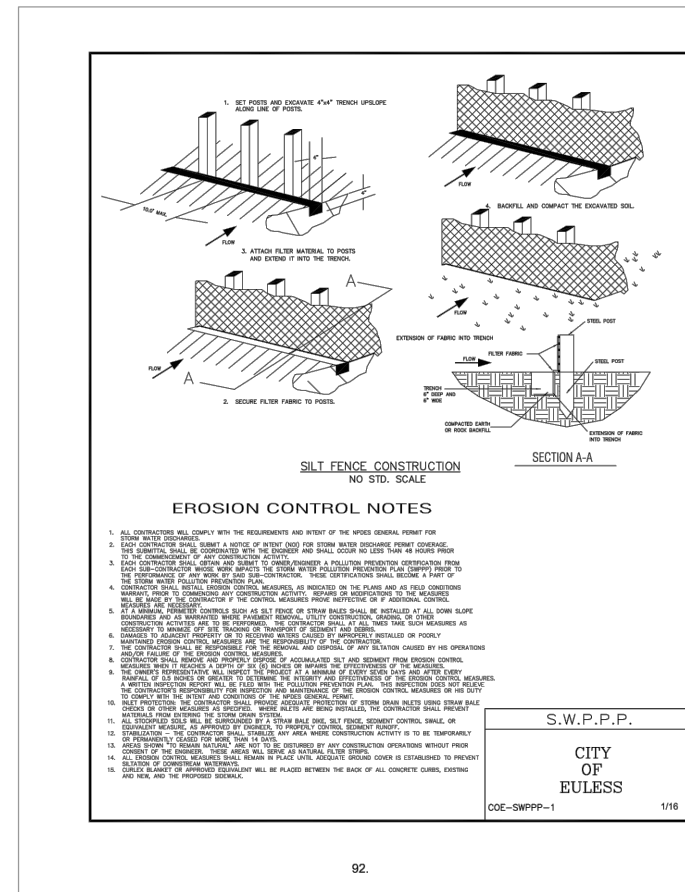
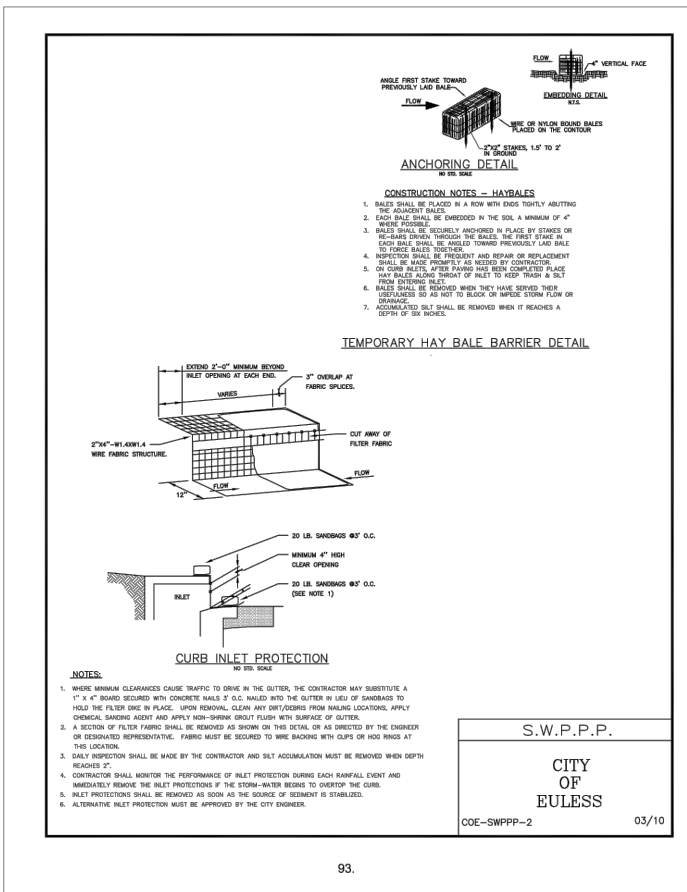
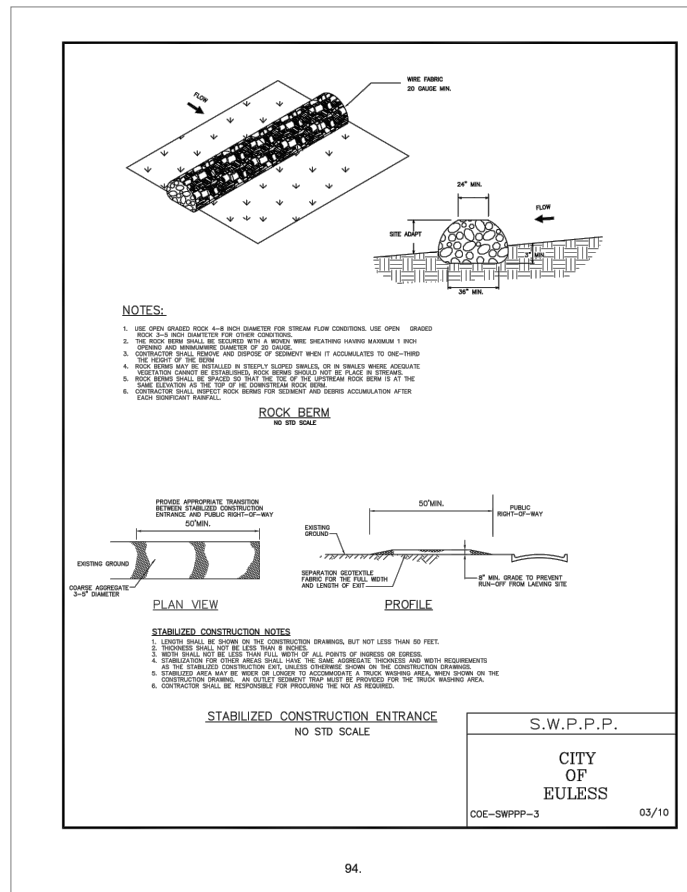

no.	revision	by	date

**CIVIL ENGINEERING**  
202 REPUBLIC LN  
EULESS, TX 76040  
PH: (972) 523-5493  
TBPE: F-19293

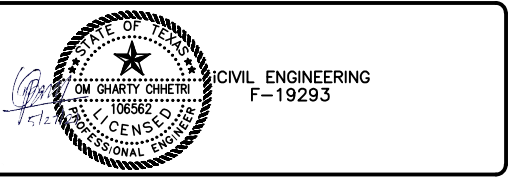

scale  
horiz  
N/A  
vert  
N/A  
date  
MAY 2021



**PRELIMINARY PLAN**  
For Review Only  
This document is released for the purpose of interim review and markup under the authority of OM GHARTY CHHETRI, P.E. Licence No: 106562 on 5/6/21. This document is not to be used for construction, bidding or permit purposes.

**STANDARD DETAILS**  
**NEPALI CULTURAL AND SPIRITUAL CENTER**  
PHASE-1  
1212 ROYAL PARKWAY, EULESS TEXAS 76040

PROJECT NO.  
JN 1120

- NOTES:
1. PRECAST MANHOLE TO MEET ALL REQUIREMENTS OF ASTM C-478.
  2. O-RING GASKET JOINT REQUIRED IN ACCORDANCE WITH ASTM C-443. PREFORMED PLASTIC GASKET, I.E. RAM-NEK MAY ALSO BE USED.
  3. EACH INDIVIDUAL SECTION OF THE PRECAST MANHOLE MUST BE STAMPED WITH THE ASTM SPECIFICATION NUMBER, THE MANUFACTURER'S NAME, AND DATE MANUFACTURED.
  4. MANHOLE BACKFILL SHALL CONSIST OF 2 SACK FLOWABLE FILL WHEN LOCATED IN PAVED AREAS.
  4. SERVICES WHICH ARE CONNECTED TO MANHOLES SHALL BE INSTALLED A MINIMUM OF 6 INCHES ABOVE THE MAIN FLOWLINE.

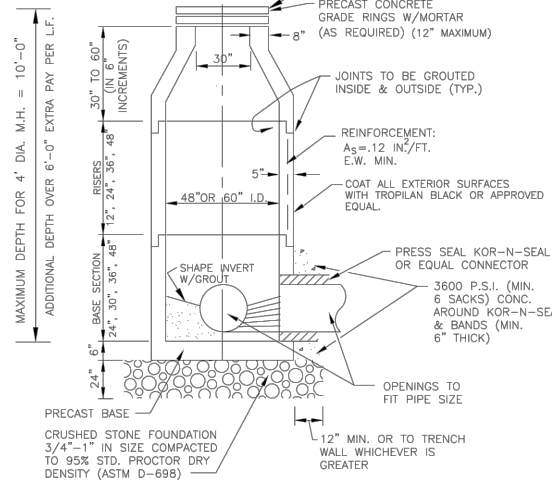

TYPICAL 48" DIA. MANHOLE (WITH PRECAST BASE & FACTORY INVERT)

48" PRECAST MANHOLE
CITY OF EULESS
COE-PCMH 8/13

40.

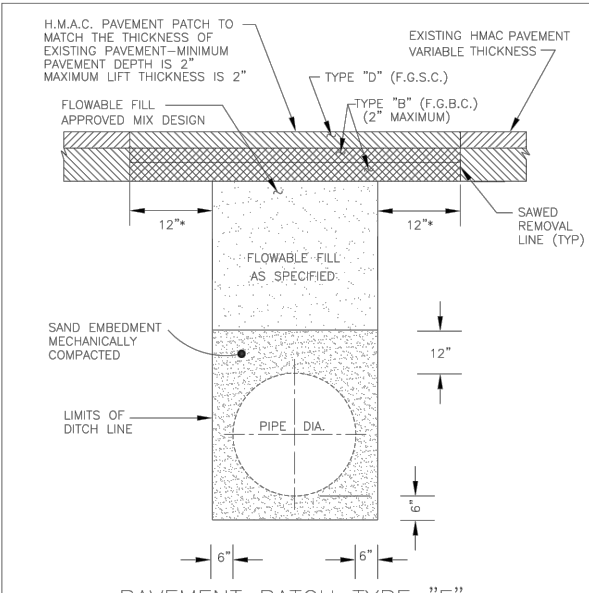

PAVEMENT PATCH TYPE "F"

FLOWABLE FILL DESIGN VALUE			
TEST NO.	TEST TYPE	TEST VALUE	DESIGN VALUE
1	SLUMP	200	210
2	COMPRESSIVE STRENGTH	3000	3000
3	SET TIME	15	15
4	FLOW	1.0	1.0
5	TEMPERATURE	100	100
6	WATER	14.88	14.88
7	WATER REDUCER	0.561	0.561
8	REINFORCING FIBER	5.4	5.4

1 CUBIC YARD MIX PROPORTIONS

CEMENT	1150	7.15	0.28
PORTLAND CEMENT	1150	7.15	0.28
AGGREGATE	3000	19.0	0.62
WATER	420	2.64	0.08
WATER REDUCER	56	0.35	0.01
REINFORCING FIBER	54	0.34	0.01

\*12" OVER UNDISTURBED MATERIAL

TYPE "F" PAVEMENT PATCH
CITY OF EULESS
COE-PP-4 1/15

77.

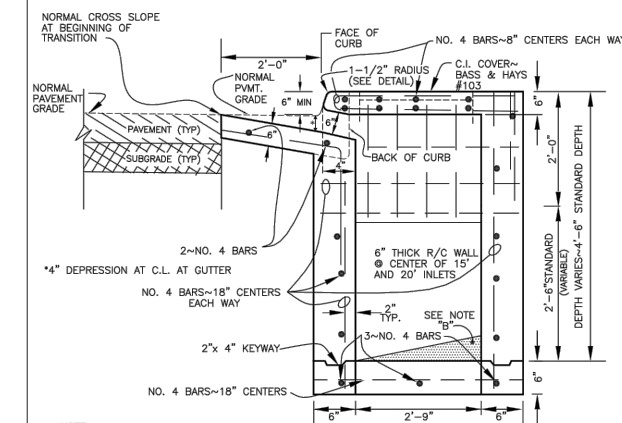

SECTION B-B

- NOTE: INSTALL CEMENT GROUT (1 PART CEMENT, 2 PARTS SHARP SAND) FROM PIPE INVERT AT INLET TO ALL WALLS OF THE INLET AT A SLOPE OF N.L.T. 1/4" PER 12". LONGITUDINAL AND TRANSVERSE REINFORCEMENT IN THE INLET TOP SHALL BE STOPPED 1-1/2" FROM THE MANHOLE RING ON ALL SIDES. SEE PLAN VIEW FOR ADDITIONAL DIAGONAL REINFORCEMENT AROUND MANHOLE RING.

- GENERAL NOTES:
1. CONSTRUCTION SPECIFICATIONS SHALL BE THE 1993 EDITION OF THE "STANDARD SPECIFICATIONS FOR CONSTRUCTION OF HIGHWAYS, STREETS, AND BRIDGES" AS PUBLISHED BY THE TxDOT.
  2. ALL CONCRETE SHALL BE CONCRETE HAVING A MINIMUM COMPRESSIVE STRENGTH OF 3000 P.S.I. IN 28 DAYS, TYPE 2 WHITE PIGMENTED CURING COMPOUND IS REQUIRED.
  3. ALL EXPOSED CORNERS SHALL BE CHAMFERED 3/4" UNLESS OTHERWISE NOTED.
  4. REINFORCING STEEL SHALL BE ASTM A615-GRADE 40.
  5. ALL BACKFILL AROUND THE INLETS SHALL BE MECHANICALLY TAMPED TO 95% OF THE STANDARD PROCTOR DENSITY, ASTM-D-698, WET SIDE OF OPTIMUM.
  6. REMOVAL AND DISPOSAL OFF OF THE PROJECT SITE OF EXISTING CURB AND GUTTER TO ACCOMMODATE INLET CONSTRUCTION IS SUBSIDIARY TO THE UNIT PRICE BID PER EACH FOR VARIOUS SIZES OF CURB INLETS.
  7. OUTSIDE FORMS ON INLETS ARE REQUIRED.

CURB INLET DETAIL (NON-RECESSED)
CITY OF EULESS
COE-NRC 1 6/08

55.

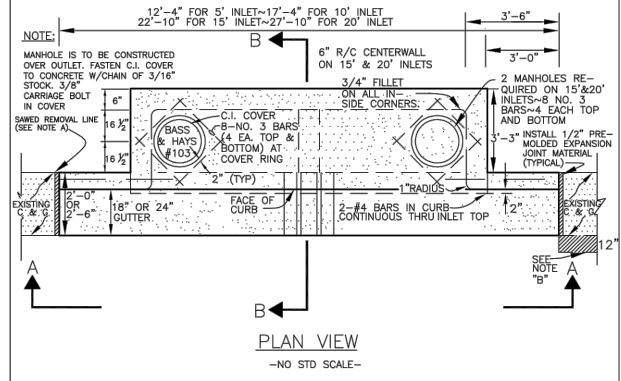

PLAN VIEW

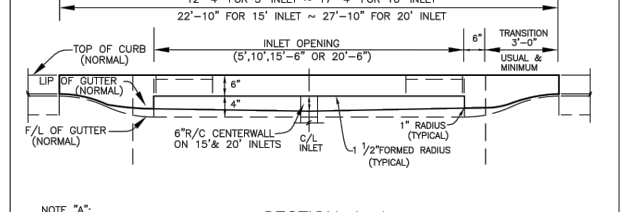

SECTION A-A

CURB INLET DETAILS (NON-RECESSED)
CITY OF EULESS
COE-NRC 3 8/10

57.

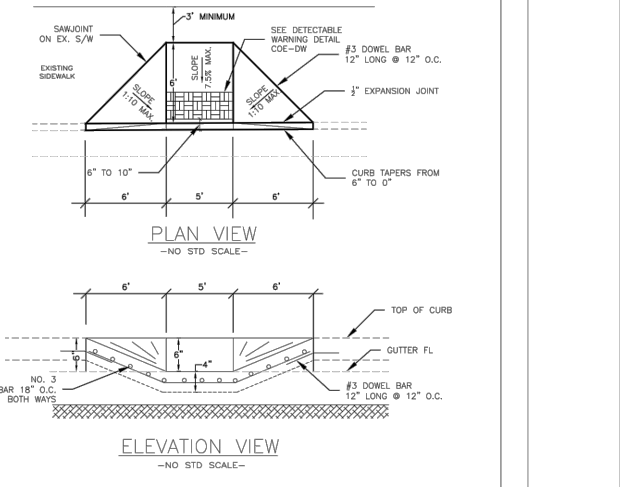

TYPE E RAMP

- NOTES:
1. ALL EXISTING CONCRETE TO BE REMOVED SHALL BE SAWEED.
  2. ALL CONCRETE SHALL HAVE A 3000 PSI 28 DAY COMPRESSIVE STRENGTH.
  3. TYPE 2 WHITE PIGMENTED CURING COMPOUND SHALL BE APPLIED TO ALL NEW CONCRETE.
  4. RAMPS AND SIDEWALK SHALL RECEIVE A LIGHT BROOM FINISH, PERPENDICULAR TO THE DIRECTION OF TRAVEL.
  5. ALL RAMPS SHALL HAVE TRUNCATED DOME BRICK INSTALLED IN BRICK RED COLOR. THE SLOPE SHALL BE LESS THAN OR EQUAL TO 7.5%. SEE DETAIL COE-DW FOR CONSTRUCTION OF DETECTABLE WARNING SECTION OF RAMP.
  6. INSTALL 1/2-INCH PREFORMED BITUMINOUS FIBER EXPANSION JOINT AS SHOWN AND AS NOTED.
  7. REINFORCEMENT IN EXISTING CURB AND GUTTER SHALL EXTEND TO THE NEW RAMP CONSTRUCTION. PLACE NO. 3 REBAR AT 18" CENTERS BOTH WAYS. PROVIDE 12" LONG NO. 3 DOWELS TO THE NEW SIDEWALK/RAMPS TO EXISTING SIDEWALK AT 12" O.C.
  8. LANDINGS SHALL BE 5' X 5' AND HAVE A SLOPE LESS THAN 1.5%.
  9. THE BOTTOM OF DIAGONAL CURB RAMPS SHALL HAVE 48 INCHES MINIMUM CLEAR SPACE. MARKED CROSSINGS SHALL HAVE 48 IN CLEAR SPACE WITHIN THE MARKINGS.
  10. FLARED SIDES SHALL HAVE AT LEAST A 24 INCH LONG SEGMENT OF CURB LOCATED ON EACH SIDE OF THE CURB RAMP WITHIN THE MARKED CROSSING.

TYPE E RAMP
CITY OF EULESS
COE-HC-5 11/16

83.

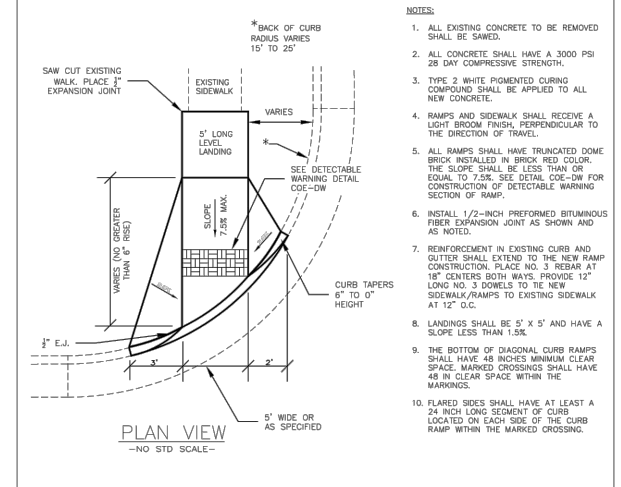

TYPE A RAMP

- NOTES:
1. ALL EXISTING CONCRETE TO BE REMOVED SHALL BE SAWEED.
  2. ALL CONCRETE SHALL HAVE A 3000 PSI 28 DAY COMPRESSIVE STRENGTH.
  3. TYPE 2 WHITE PIGMENTED CURING COMPOUND SHALL BE APPLIED TO ALL NEW CONCRETE.
  4. RAMPS AND SIDEWALK SHALL RECEIVE A LIGHT BROOM FINISH, PERPENDICULAR TO THE DIRECTION OF TRAVEL.
  5. ALL RAMPS SHALL HAVE TRUNCATED DOME BRICK INSTALLED IN BRICK RED COLOR. THE SLOPE SHALL BE LESS THAN OR EQUAL TO 7.5%. SEE DETAIL COE-DW FOR CONSTRUCTION OF DETECTABLE WARNING SECTION OF RAMP.
  6. INSTALL 1/2-INCH PREFORMED BITUMINOUS FIBER EXPANSION JOINT AS SHOWN AND AS NOTED.
  7. REINFORCEMENT IN EXISTING CURB AND GUTTER SHALL EXTEND TO THE NEW RAMP CONSTRUCTION. PLACE NO. 3 REBAR AT 18" CENTERS BOTH WAYS. PROVIDE 12" LONG NO. 3 DOWELS TO THE NEW SIDEWALK/RAMPS TO EXISTING SIDEWALK AT 12" O.C.
  8. LANDINGS SHALL BE 5' X 5' AND HAVE A SLOPE LESS THAN 1.5%.
  9. THE BOTTOM OF DIAGONAL CURB RAMPS SHALL HAVE 48 INCHES MINIMUM CLEAR SPACE. MARKED CROSSINGS SHALL HAVE 48 IN CLEAR SPACE WITHIN THE MARKINGS.
  10. FLARED SIDES SHALL HAVE AT LEAST A 24 INCH LONG SEGMENT OF CURB LOCATED ON EACH SIDE OF THE CURB RAMP WITHIN THE MARKED CROSSING.

TYPE A RAMP
CITY OF EULESS
COE-HC-1 11/16

80.

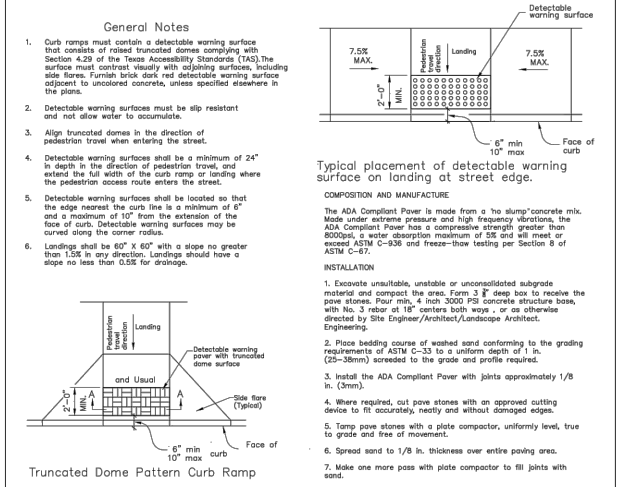

DETECTABLE WARNING PAVER (OPTION)

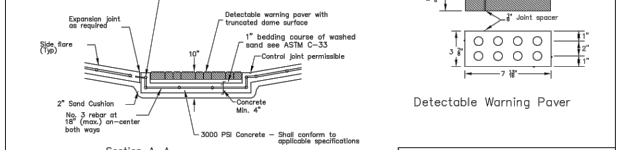

DETECTABLE WARNINGS
CITY OF EULESS
COE-DW 04/12

79.

iCIVIL ENGINEERING  
202 REPUBLIC LN  
EULESS, TX 76040  
PH: (972) 523-5493  
TBPE: F-19293

iCIVIL ENGINEERING  
F-19293

scale  
horiz  
N/A  
vert  
N/A  
date  
MAY 2021



PRELIMINARY PLAN  
For Review Only  
This document is released for the purpose of interim review and markup under the authority of OM GHARTY CHHETRI, P.E. Licence No: 106562 on 5/6/21. This document is not to be used for construction, bidding or permit purposes.

STANDARD DETAILS  
NEPALI CULTURAL AND SPIRITUAL CENTER  
PHASE-1  
1212 ROYAL PARKWAY, EULESS TEXAS 76040

PROJECT NO.  
JN 1120

no.	revision	by	date

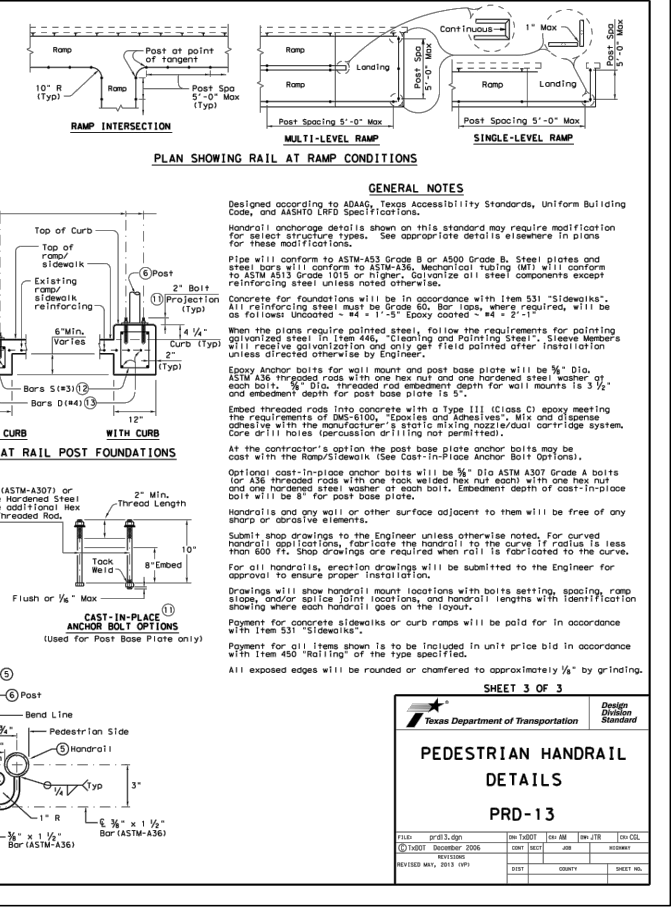
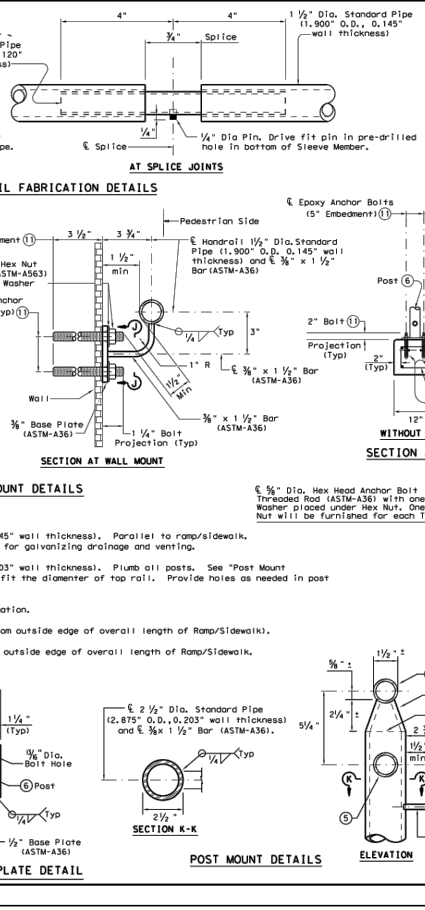
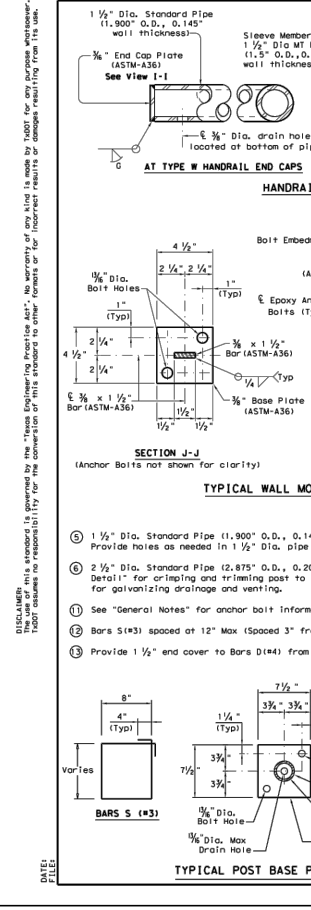
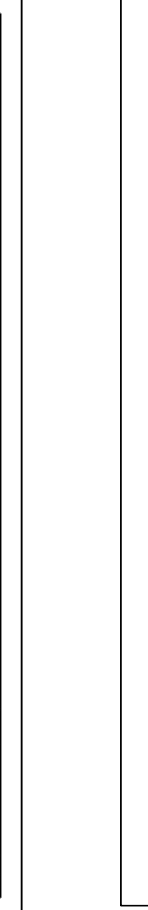
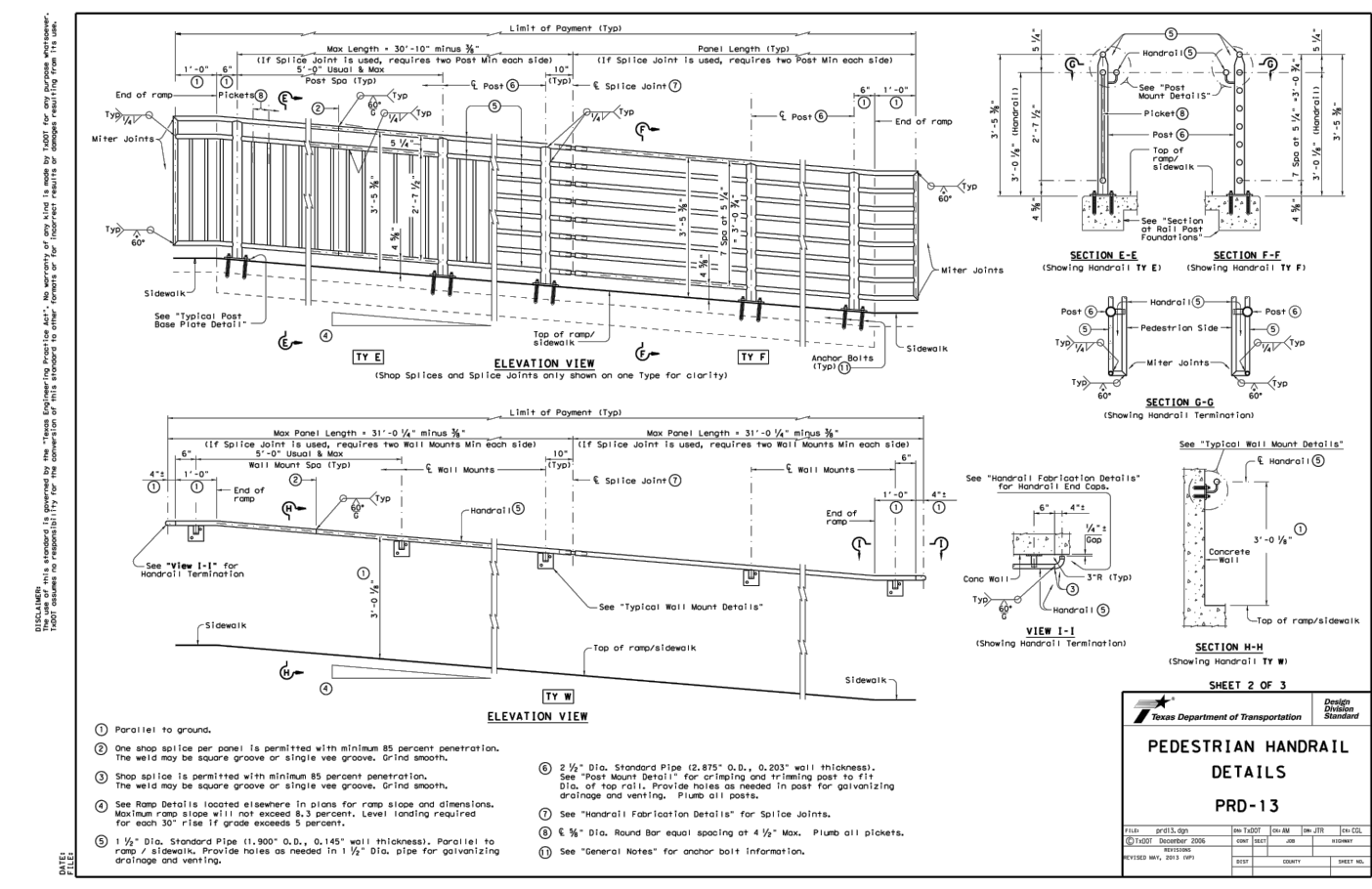

**TABLE OF VARIABLE DIMENSIONS AND QUANTITIES FOR ONE HEADWALL**

*Values for One Pipe* | *Values to be Added for Each Additional Pipe*

Span (ft) / Dia (in)	W	X	Y	L	Reinf. (Lbs)	Conc. (CY)	X and W	Reinf. (Lbs)	Conc. (CY)
12'-0" / 48"	4'-7 1/2"	2'-0"	7'-10"	3'-3 1/2"	88.06	1.9	7'-9"	20.02	0.2
15'-0" / 60"	5'-5 1/2"	2'-9 1/2"	3'-4"	3'-10 1/2"	103.07	2.2	2'-2"	24.03	0.3
18'-0" / 72"	6'-4 1/2"	3'-1"	3'-10"	4'-5"	124.09	2.6	2'-8"	32.03	0.4
21'-0" / 84"	7'-2 1/2"	3'-4 1/2"	4'-2"	5'-0"	143.11	3.0	3'-1"	43.04	0.5
24'-0" / 96"	8'-2 1/2"	3'-8 1/2"	4'-10"	5'-2"	164.13	3.5	3'-7"	50.05	0.6
27'-0" / 108"	9'-1"	4'-1"	5'-4"	6'-2"	179.15	3.9	3'-11"	56.06	0.6
30'-0" / 120"	9'-11 1/2"	4'-4 1/2"	5'-10"	6'-8 1/2"	203.17	4.4	4'-4"	65.08	0.8
33'-0" / 132"	10'-10"	4'-8"	6'-2"	7'-3 1/2"	224.20	4.8	4'-8"	71.09	1.0
36'-0" / 144"	11'-8 1/2"	4'-11 1/2"	6'-10"	7'-10 1/2"	248.22	5.3	5'-1"	81.10	1.2
42'-0" / 168"	13'-5 1/2"	5'-6 1/2"	7'-10"	9'-0 1/2"	298.28	6.3	5'-10"	97.13	1.7
48'-0" / 192"	15'-9"	6'-1 1/2"	9'-4"	10'-9 1/2"	360.38	8.7	7'-7"	117.17	2.4
54'-0" / 216"	17'-5 1/2"	6'-8 1/2"	10'-4"	11'-1 1/2"	429.43	11.1	8'-7"	151.21	3.4
60'-0" / 240"	19'-2 1/2"	7'-3 1/2"	11'-4"	12'-1 1/2"	481.53	13.6	9'-2"	174.25	5.0
66'-0" / 264"	20'-11 1/2"	7'-10 1/2"	12'-4"	13'-3"	544.62	16.0	9'-9"	194.29	7.0
72'-0" / 288"	22'-8 1/2"	8'-5 1/2"	13'-4"	14-0"	601.71	18.4	9'-4"	213.33	9.6

*Values to be Added for Each Additional Pipe*

Span (ft) / Dia (in)	W	X	Y	L	Reinf. (Lbs)	Conc. (CY)
12'-0" / 48"	2'-0"	4'-1"	4'-11"	1'-8"	118.08	1.9
15'-0" / 60"	2'-9 1/2"	3'-0"	5'-9 1/2"	1'-11"	139.11	2.2
18'-0" / 72"	3'-1"	3'-9"	6'-7 1/2"	1'-10"	161.13	2.6
21'-0" / 84"	3'-4 1/2"	3'-4 1/2"	7'-4"	1'-9"	183.15	3.0
24'-0" / 96"	3'-8 1/2"	3'-8 1/2"	8'-1"	1'-8"	205.17	3.5
27'-0" / 108"	4'-1"	4'-1"	8'-11"	1'-7"	227.20	3.9
30'-0" / 120"	4'-4 1/2"	4'-4 1/2"	9'-8 1/2"	1'-6"	249.22	4.4
33'-0" / 132"	4'-8"	4'-8"	10'-5 1/2"	1'-5"	271.25	4.8
36'-0" / 144"	5'-0 1/2"	5'-0 1/2"	11'-2 1/2"	1'-4"	293.28	5.3
42'-0" / 168"	6'-1 1/2"	6'-1 1/2"	12'-11"	1'-3"	355.38	7.7
48'-0" / 192"	7'-2 1/2"	7'-2 1/2"	14'-10"	1'-2"	417.43	10.1
54'-0" / 216"	8'-3 1/2"	8'-3 1/2"	16'-9 1/2"	1'-1"	479.48	12.5
60'-0" / 240"	9'-4 1/2"	9'-4 1/2"	18'-8 1/2"	1'-0"	541.53	14.9
66'-0" / 264"	10'-5 1/2"	10'-5 1/2"	20'-7 1/2"	1'-0"	603.58	17.3
72'-0" / 288"	11'-6 1/2"	11'-6 1/2"	22'-6 1/2"	1'-0"	665.63	19.7

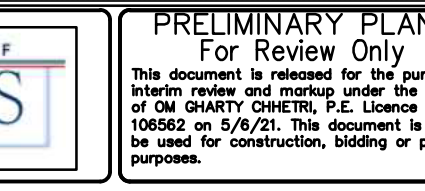
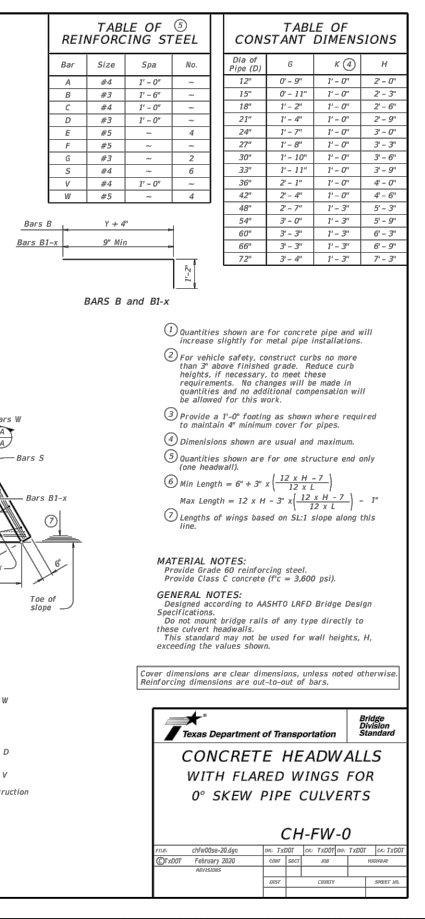
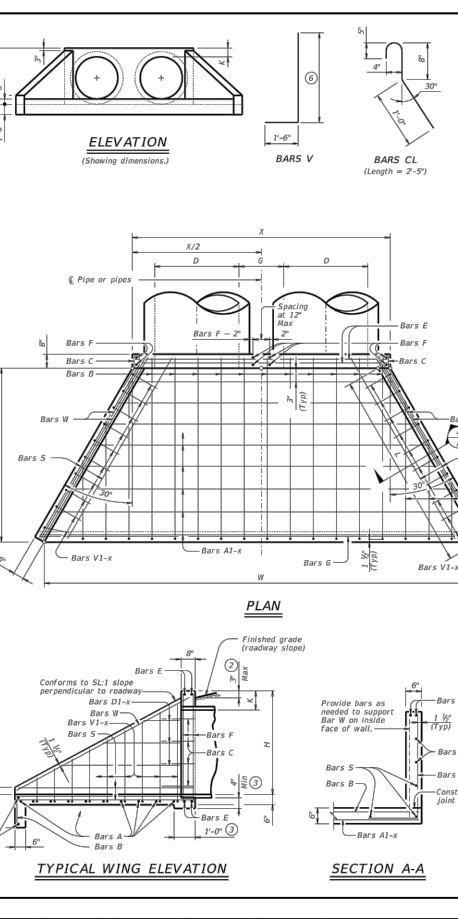

no.	revision	by	date

**CIVIL ENGINEERING**  
202 REPUBLIC LN  
EULESS, TX 76040  
PH: (972) 523-5493

**TBPE: F-19293**

**CIVIL ENGINEERING**  
F-19293

scale  
horiz  
N/A  
vert  
N/A  
date  
MAY 2021



**PRELIMINARY PLAN**  
For Review Only

This document is released for the purpose of interim review and markup under the authority of OM GHARTY CHHETRI, P.E. License No: 106562 on 5/6/21. This document is not to be used for construction, bidding or permit purposes.

STANADARD DETAILS

**NEPALI CULTURAL AND SPIRITUAL CENTER**  
**PHASE-I**

1212 ROYAL PARKWAY, EULESS TEXAS 76040

PROJECT NO.  
JN 1120

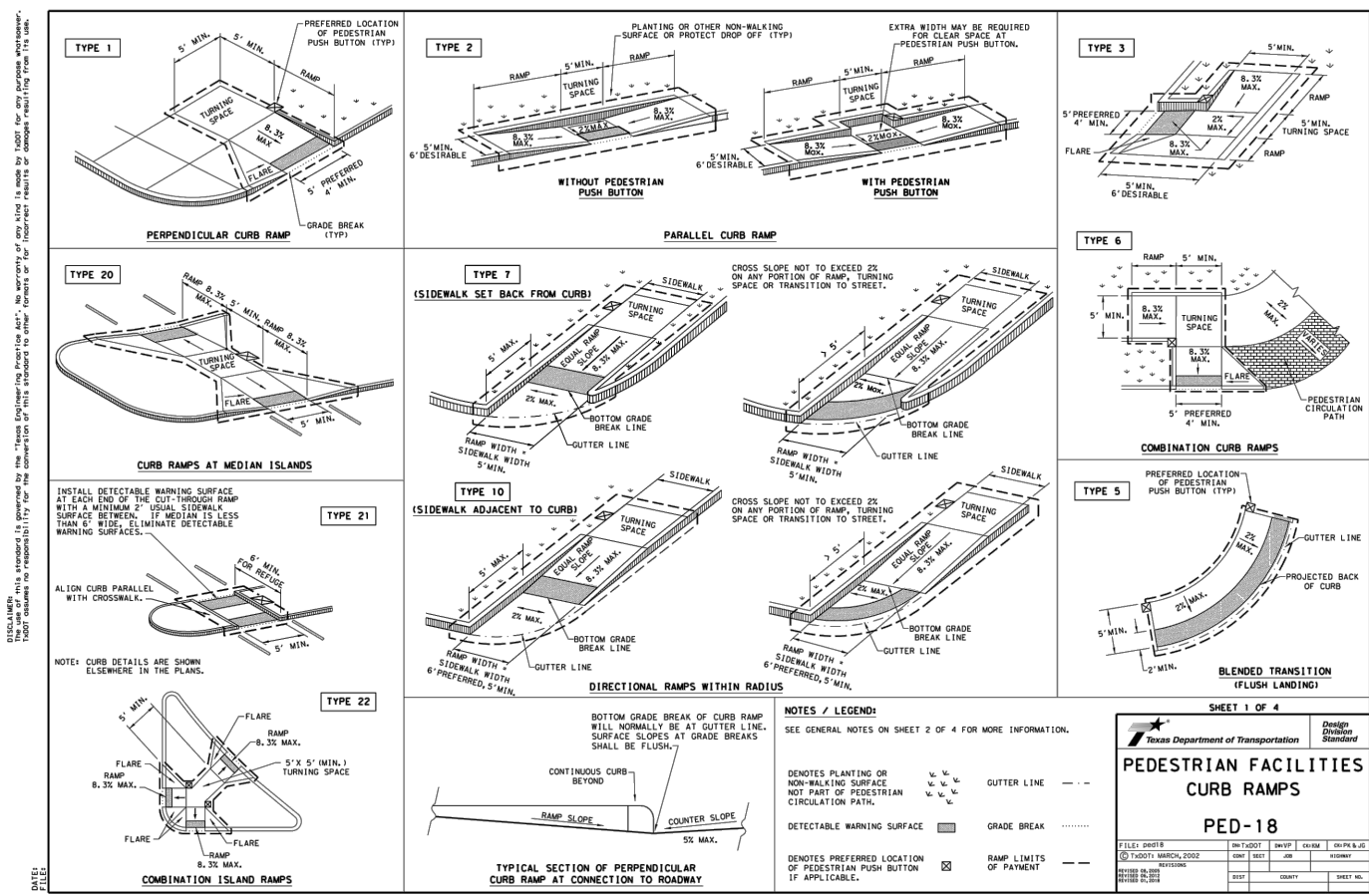

**PEDESTRIAN FACILITIES CURB RAMPS PED-18**

FILE: DPFB | DWG: TDDOT | SWP: | CHW: | DWP: | JG: | TDDOT | MARCH, 2002 | DWG | SWP | CHW | DWP | JG | TDDOT | MARCH, 2002 | DWG | SWP | CHW | DWP | JG | TDDOT | MARCH, 2002 | DWG | SWP | CHW | DWP | JG

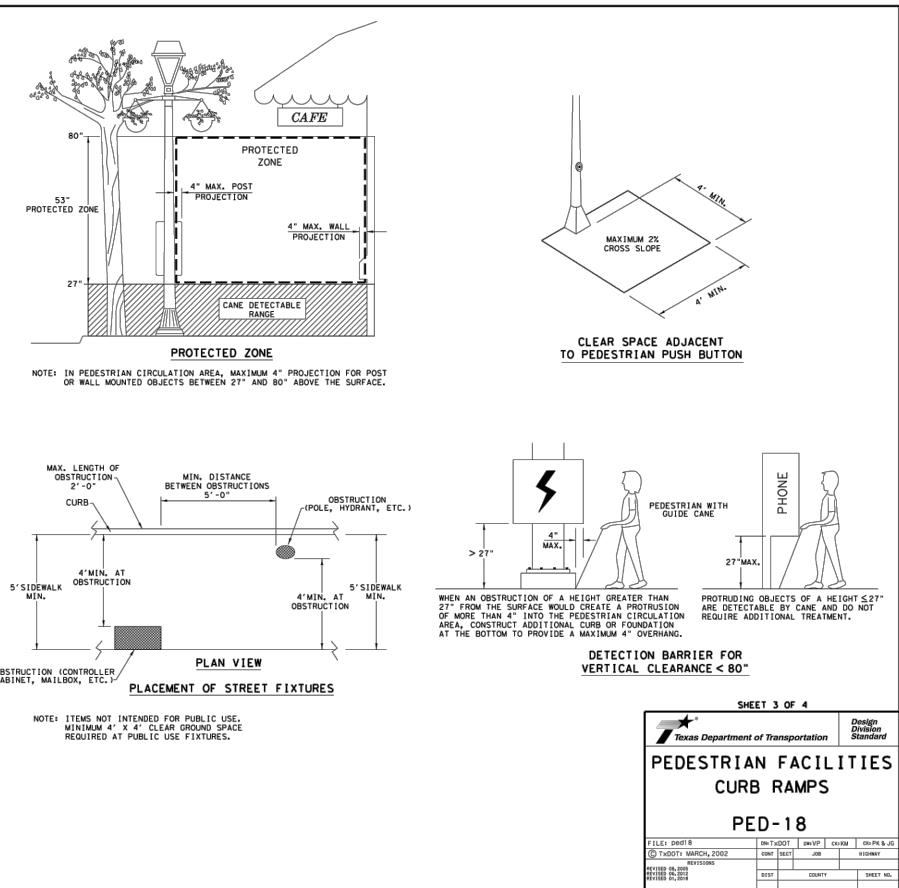
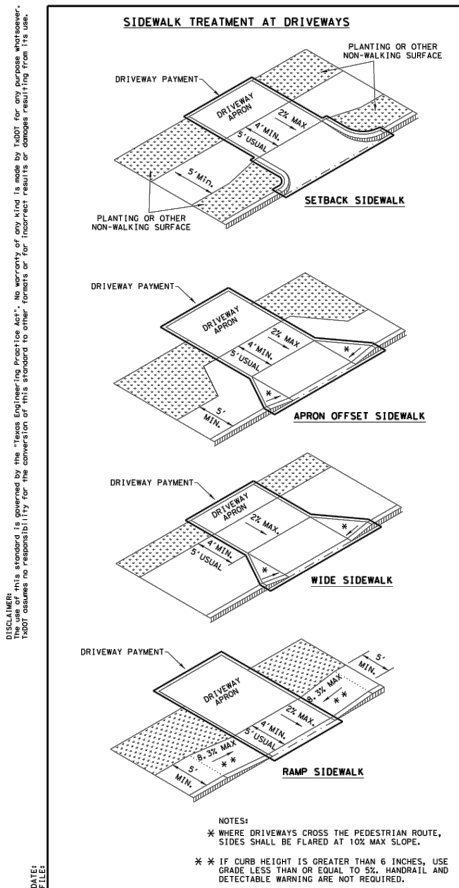

**PEDESTRIAN FACILITIES CURB RAMPS PED-18**

FILE: DPFB | DWG: TDDOT | SWP: | CHW: | DWP: | JG: | TDDOT | MARCH, 2002 | DWG | SWP | CHW | DWP | JG | TDDOT | MARCH, 2002 | DWG | SWP | CHW | DWP | JG | TDDOT | MARCH, 2002 | DWG | SWP | CHW | DWP | JG

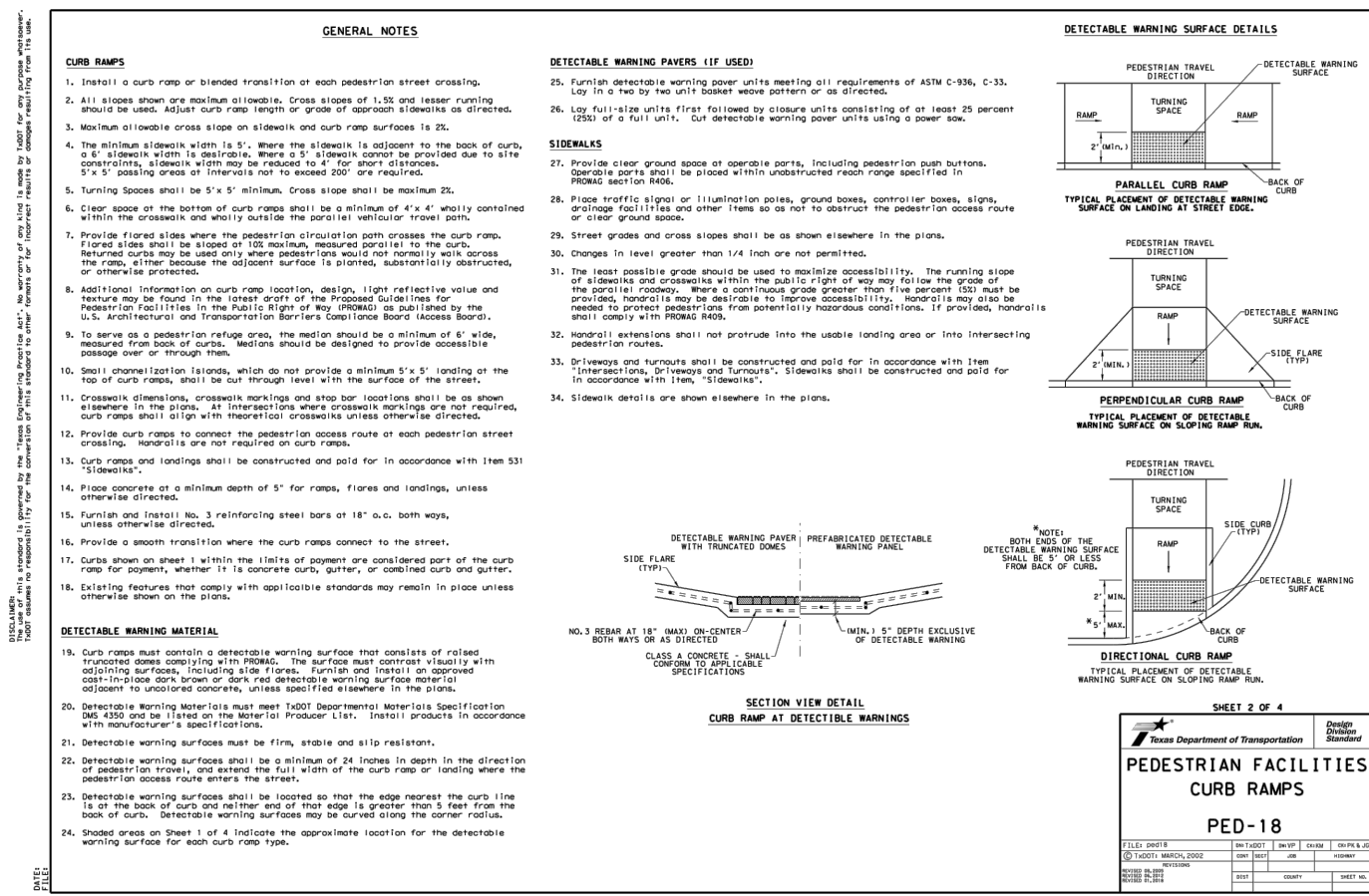

**PEDESTRIAN FACILITIES CURB RAMPS PED-18**

FILE: DPFB | DWG: TDDOT | SWP: | CHW: | DWP: | JG: | TDDOT | MARCH, 2002 | DWG | SWP | CHW | DWP | JG | TDDOT | MARCH, 2002 | DWG | SWP | CHW | DWP | JG | TDDOT | MARCH, 2002 | DWG | SWP | CHW | DWP | JG

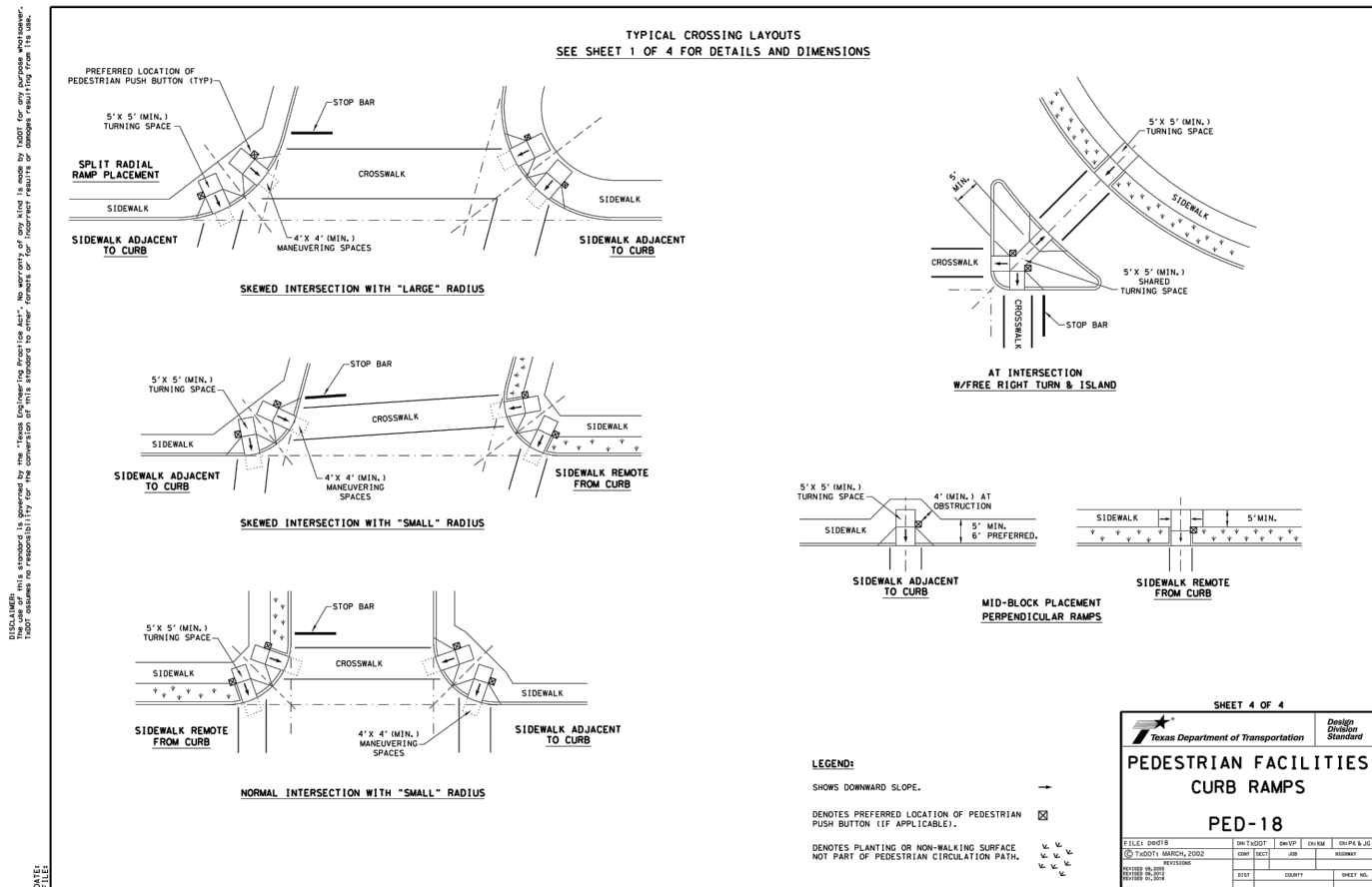

**PEDESTRIAN FACILITIES CURB RAMPS PED-18**

FILE: DPFB | DWG: TDDOT | SWP: | CHW: | DWP: | JG: | TDDOT | MARCH, 2002 | DWG | SWP | CHW | DWP | JG | TDDOT | MARCH, 2002 | DWG | SWP | CHW | DWP | JG | TDDOT | MARCH, 2002 | DWG | SWP | CHW | DWP | JG

no.	revision	by	date

iCIVIL ENGINEERING  
202 REPUBLIC LN  
EULESS, TX 76040  
PH: (972) 523-5493  
TBPE: F-19293

scale  
horiz N/A  
vert N/A  
date  
MAY 2021

PRELIMINARY PLAN  
For Review Only  
This document is released for the purpose of interim review and markup under the authority of OM GHARTY CHHETRI, P.E. Licence No: 106562 on 5/6/21. This document is not to be used for construction, bidding or permit purposes.

STANDARD DETAILS  
NEPALI CULTURAL AND SPIRITUAL CENTER  
PHASE-1  
1212 ROYAL PARKWAY, EULESS TEXAS 76040

PROJECT NO.  
JN 1120

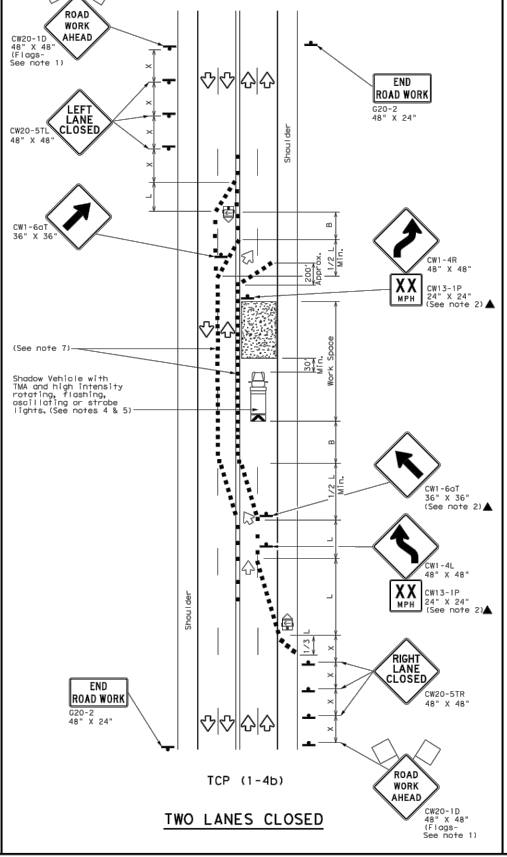
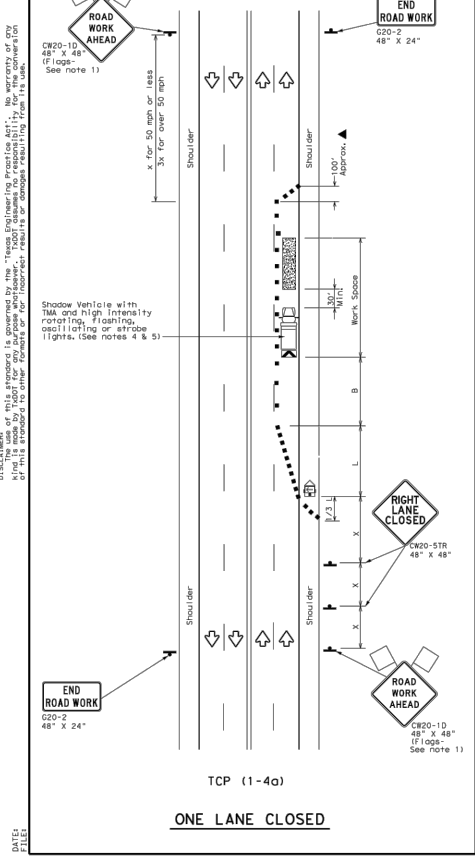

Posted Speed (mph)	Formula	Minimum Taper Length (ft)	Suggested Maximum Spacing of Channelizing Devices (ft)	Minimum Sign Spacing (ft)	Suggested Longitudinal Buffer Space (ft)
30	$10' + \frac{150' - 10'}{S}$	150'	30'	120'	90'
35	$10' + \frac{165' - 10'}{S}$	165'	30'	120'	90'
40	$10' + \frac{180' - 10'}{S}$	180'	30'	120'	90'
45	$10' + \frac{195' - 10'}{S}$	195'	30'	120'	90'
50	$10' + \frac{210' - 10'}{S}$	210'	30'	120'	90'
55	$10' + \frac{225' - 10'}{S}$	225'	30'	120'	90'
60	$10' + \frac{240' - 10'}{S}$	240'	30'	120'	90'
65	$10' + \frac{255' - 10'}{S}$	255'	30'	120'	90'
70	$10' + \frac{270' - 10'}{S}$	270'	30'	120'	90'
75	$10' + \frac{285' - 10'}{S}$	285'	30'	120'	90'

TCP	TITLE	MOBILE	SHORT DURATION	SHORT TERM STATIONARY	INTERMEDIATE TERM STATIONARY	LONG TERM STATIONARY
1-1	CONVENTIONAL ROAD SHOULDER WORK		✓	✓		
1-2	ONE-LANE TWO-WAY TRAFFIC CONTROL		✓	✓		
1-3	TRAFFIC SHIFTS ON TWO-LANE ROADS		✓	✓		
1-4	LANE CLOSURES ON MULTILANE CONVENTIONAL ROADS		✓	✓		
1-5	LANE CLOSURES FOR DIVIDED HIGHWAYS		✓	✓		
1-6	AUTOMATED FLAGGER ASSISTANCE DEVICES (AFADS)		✓	✓		
2-1	CONVENTIONAL ROAD SHOULDER WORK	✓			✓	
2-2	ONE-LANE TWO-WAY TRAFFIC CONTROL		✓	✓	✓	
2-3	TRAFFIC SHIFTS ON TWO-LANE ROADS		✓	✓	✓	
2-4	LANE CLOSURES ON MULTILANE CONVENTIONAL ROADS		✓	✓	✓	
2-5	LONG TERM LANE CLOSURES MULTILANE CONVENTIONAL ROADS		✓	✓	✓	✓
2-6	LANE CLOSURES ON DIVIDED HIGHWAYS		✓	✓	✓	✓
2-7	DIVERSIONS AND NARROW BRIDGES		✓	✓	✓	✓
2-8	LONG TERM ONE-LANE TWO-WAY CONTROL		✓	✓	✓	✓
3-1	MOBILE OPERATIONS UNDIVIDED HIGHWAYS	✓				
3-2	MOBILE OPERATIONS DIVIDED HIGHWAYS	✓				
3-3	MOBILE OPERATIONS RAISED PAVEMENT MARKER INSTALLATION/REMOVAL	✓				
3-4	MOBILE OPERATIONS FOR ISOLATED WORK AREAS UNDIVIDED HIGHWAYS	✓				
3-5	MOBILE OPERATIONS HERBICIDE TRUCK OPERATIONS	✓				
4-1	SHOULDER WORK FOR FREEWAYS / EXPRESSWAYS		✓ (15-1a only)	✓ (15-1b only)	✓ (15-1b only)	
6-1	FREEWAY LANE CLOSURES		✓	✓	✓	✓
6-2	WORK AREA NEAR RAMP		✓	✓	✓	✓
6-3	WORK AREA BEYOND RAMP		✓	✓	✓	✓
6-4	WORK AREA AT EXIT RAMP		✓	✓	✓	✓
6-5	WORK AREA BEYOND EXIT RAMP		✓	✓	✓	✓
6-6	FREEWAY CLOSURE		✓	✓	✓	✓
6-7	SHORT DURATION FREEWAY CLOSURE SEQUENCE		✓	✓	✓	✓
6-8	WORK IN EXIT GORE FOR ADT GREATER THAN 10,000		✓	✓	✓	✓
6-9	WORK IN EXIT GORE FOR ADT LESS THAN 10,000		✓	✓	✓	✓
7-1	TRAFFIC CONTROL DETAILS FOR SURFACING OPERATIONS		✓	✓	✓	✓

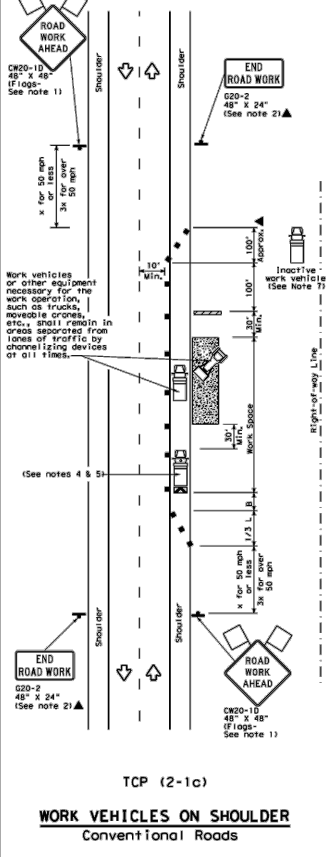
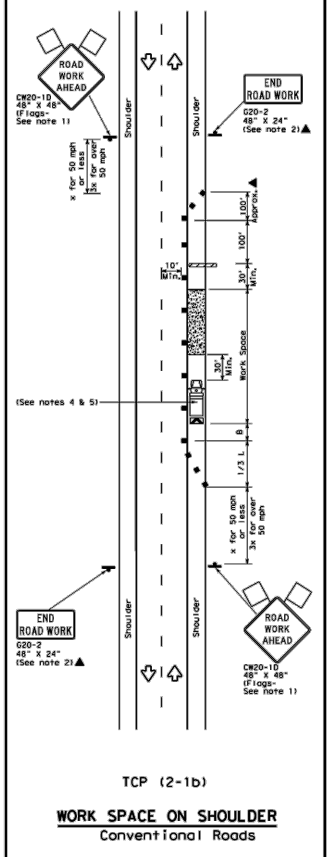
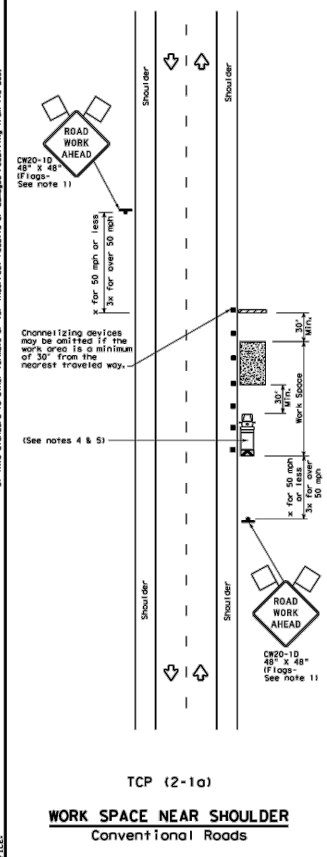
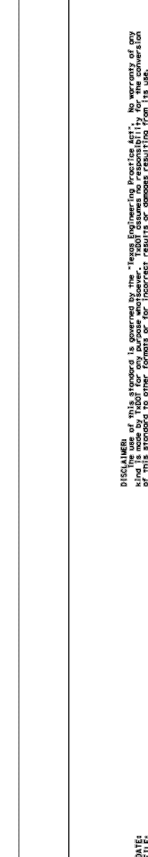

Posted Speed (mph)	Formula	Minimum Taper Length (ft)	Suggested Maximum Spacing of Channelizing Devices (ft)	Minimum Sign Spacing (ft)	Suggested Longitudinal Buffer Space (ft)
30	$10' + \frac{150' - 10'}{S}$	150'	30'	120'	90'
35	$10' + \frac{165' - 10'}{S}$	165'	30'	120'	90'
40	$10' + \frac{180' - 10'}{S}$	180'	30'	120'	90'
45	$10' + \frac{195' - 10'}{S}$	195'	30'	120'	90'
50	$10' + \frac{210' - 10'}{S}$	210'	30'	120'	90'
55	$10' + \frac{225' - 10'}{S}$	225'	30'	120'	90'
60	$10' + \frac{240' - 10'}{S}$	240'	30'	120'	90'
65	$10' + \frac{255' - 10'}{S}$	255'	30'	120'	90'
70	$10' + \frac{270' - 10'}{S}$	270'	30'	120'	90'
75	$10' + \frac{285' - 10'}{S}$	285'	30'	120'	90'

no.	revision	by	date

iCIVIL ENGINEERING  
202 REPUBLIC LN  
EULESS, TX 76040  
PH: (972) 523-5493  
TBPE: F-19293

STATE OF TEXAS  
iCIVIL ENGINEERING  
F-19293

scale  
horiz  
N/A  
vert  
N/A  
date  
MAY 2021



PRELIMINARY PLAN  
For Review Only  
This document is released for the purpose of interim review and markup under the authority of OM GHARTY CHHETRI, P.E. Licence No: 106562 on 5/6/21. This document is not to be used for construction, bidding or permit purposes.

STANDARD DETAILS  
NEPALI CULTURAL AND SPIRITUAL CENTER  
PHASE-1  
1212 ROYAL PARKWAY, EULESS TEXAS 76040

PROJECT NO.  
JN 1120

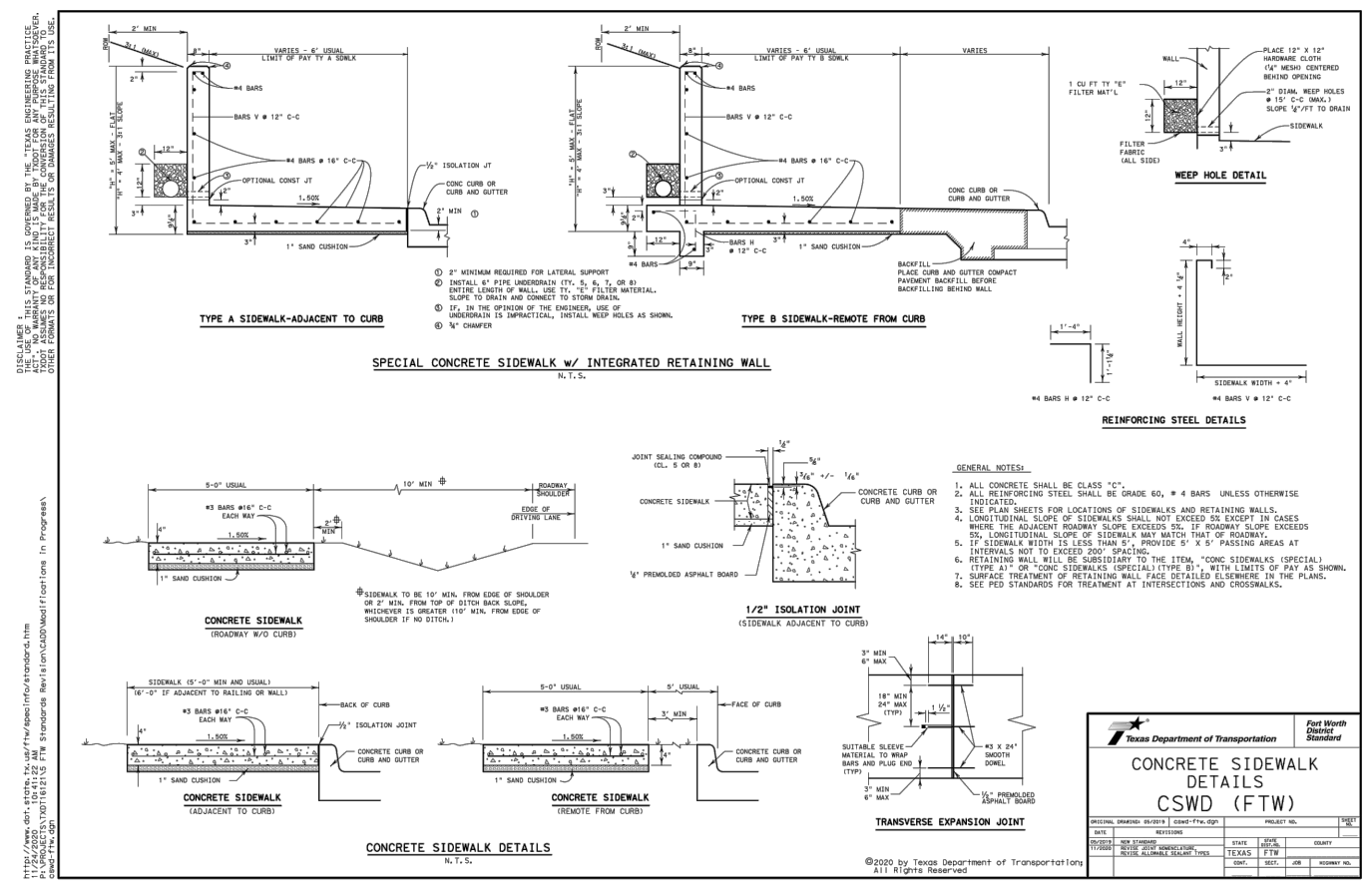
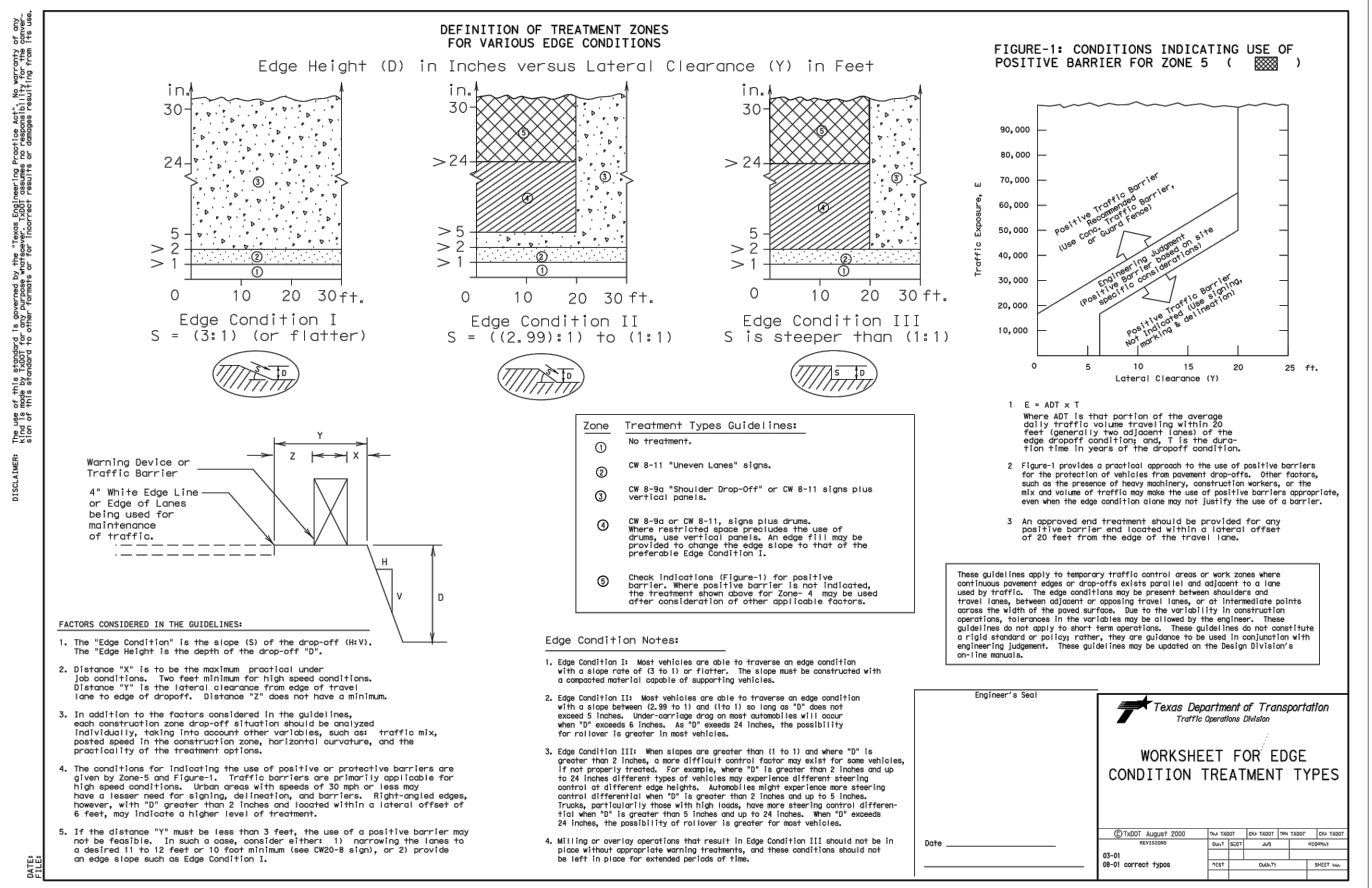
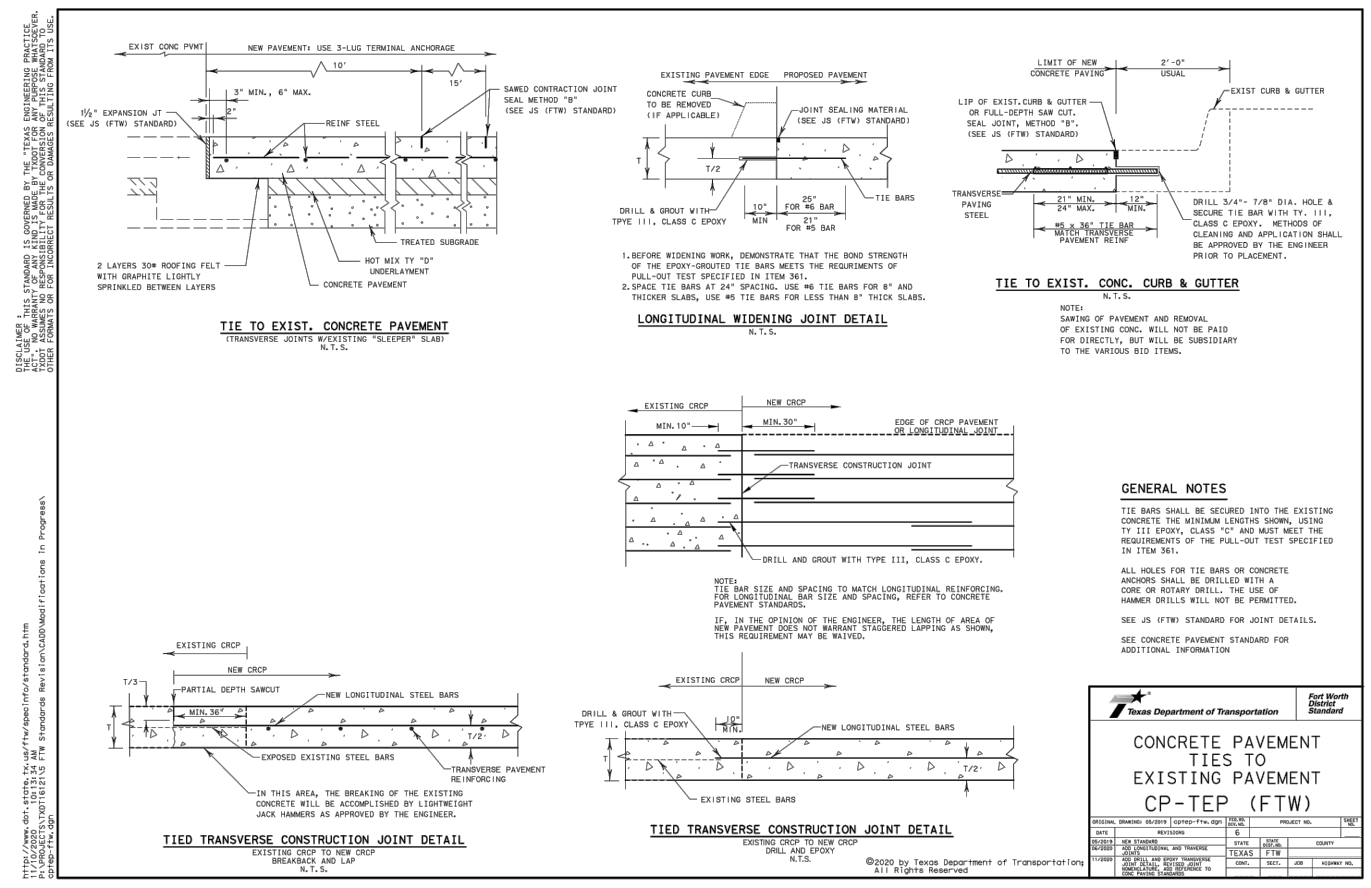

DISCLAIMER: THE USER OF THIS STANDARD IS ADVISED THAT THE TEXAS DEPARTMENT OF TRANSPORTATION HAS REVIEWED THIS STANDARD FOR TECHNICAL CORRECTNESS AND FOR CONFORMANCE WITH THE TEXAS CONSTRUCTION ACT. THE USER OF THIS STANDARD IS ADVISED THAT THE TEXAS DEPARTMENT OF TRANSPORTATION DOES NOT WARRANT ANY AND IS MADE BY THE USER OF THIS STANDARD FOR THE USER'S OWN USE. THE USER OF THIS STANDARD IS ADVISED THAT THE TEXAS DEPARTMENT OF TRANSPORTATION DOES NOT WARRANT ANY AND IS MADE BY THE USER OF THIS STANDARD FOR THE USER'S OWN USE. THE USER OF THIS STANDARD IS ADVISED THAT THE TEXAS DEPARTMENT OF TRANSPORTATION DOES NOT WARRANT ANY AND IS MADE BY THE USER OF THIS STANDARD FOR THE USER'S OWN USE.

DISCLAIMER: THE USER OF THIS STANDARD IS ADVISED THAT THE TEXAS DEPARTMENT OF TRANSPORTATION HAS REVIEWED THIS STANDARD FOR TECHNICAL CORRECTNESS AND FOR CONFORMANCE WITH THE TEXAS CONSTRUCTION ACT. THE USER OF THIS STANDARD IS ADVISED THAT THE TEXAS DEPARTMENT OF TRANSPORTATION DOES NOT WARRANT ANY AND IS MADE BY THE USER OF THIS STANDARD FOR THE USER'S OWN USE. THE USER OF THIS STANDARD IS ADVISED THAT THE TEXAS DEPARTMENT OF TRANSPORTATION DOES NOT WARRANT ANY AND IS MADE BY THE USER OF THIS STANDARD FOR THE USER'S OWN USE. THE USER OF THIS STANDARD IS ADVISED THAT THE TEXAS DEPARTMENT OF TRANSPORTATION DOES NOT WARRANT ANY AND IS MADE BY THE USER OF THIS STANDARD FOR THE USER'S OWN USE.

no.	revision	by	date

iCIVIL ENGINEERING  
202 REPUBLIC LN  
EULESS, TX 76040  
PH: (972) 523-5493

TBPE: F-19293

STATE OF TEXAS  
OM GHARTY CHHETRI  
106562  
LICENSED PROFESSIONAL ENGINEER

iCIVIL ENGINEERING  
F-19293

scale  
horiz  
N/A  
vert  
N/A  
date  
MAY 2021

THE CITY OF  
EULESS

PRELIMINARY PLAN  
For Review Only

This document is released for the purpose of interim review and markup under the authority of OM GHARTY CHHETRI, P.E. Licence No: 106562 on 5/6/21. This document is not to be used for construction, bidding or permit purposes.

STANDARD DETAILS

PROJECT NO.  
JN 1120

NEPALI CULTURAL AND SPIRITUAL CENTER  
PHASE-1

1212 ROYAL PARKWAY, EULESS TEXAS 76040

PROJECT NO.  
JN 1120





